

New Testament

ROMANS

Greek Exegesis

Lesson 25
Romans 7:1-6

I The Introduction Romans 1:1-17

II The Doctrine of the Christian Faith Romans 1:18 - 11:36

Romans 1:18 - 3:20

The Indictment: The Doctrine of Condemnation

Romans 3:21 - 5:21

The Imputation: The Doctrine of Justification

Romans 6:1 - 8:39

The Impartation: The Doctrine of Sanctification

Lesson 25
Romans 7:1-6

Diagrams

Line 2443:

(2658) Ἡ

Line 2444:

(2659) ἀγνοεῖτε,

Line 2445:

(2660) ἀδελφοί,

Line 2446:

(2661) γινώσκουσι(ν)

Line 2447:

(2662) γὰρ

Line 2448:

(2663) νόμον

Line 2449:

(2664) λαλῶ,

Line 2450:

(2665) ὅτι

Line 2451:

(2666) ὁ

Line 2452:

(2667) νόμος

Line 2453:

(2668) κυριεύει

Line 2454:

(2669) τοῦ

Line 2455:

(2670) ἀνθρώπου

Line 2456:

(2671) ἐφ'

Line 2457:

(2672) ὅσον

Line 2458:

(2673) χρόνον

Line 2459:

(2674) ζῆ;

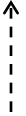

Line 2460:

(2675) ἡ

Line 2461:

(2676) γὰρ

Line 2462:

(2677) ὑπανδρος

Line 2463:

(2678) γυνή

Line 2464:

(2679) τῷ

Line 2465:

(2680) ζῶντι

Line 2466:

(2681) ἀνδρὶ

Line 2467:

(2682) δέδεται

Line 2468:

(2683) νόμῳ·

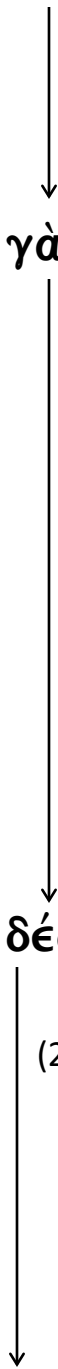

Line 2469:

(2684) **ἐὰν**

Line 2470:

(2685) **δὲ**

Line 2471:

(2686) **ἀποθάνη**

Line 2472:

(2687) **ὁ**

Line 2473:

(2688) **ἀνὴρ,**

Line 2474:

(2689) **κατήργηται**

Line 2475:

(2690) **ἀπὸ**

Line 2476:

(2691) **τοῦ**

Line 2477:

(2692) **νόμου**

Line 2478:

(2693) **τοῦ**

Line 2479:

(2694) **ἀνδρός.**

Particular laws are defined by the
Genitive of person or thing they refer to

Leviticus 14:2

This shall be the law of the leper in the day of his cleansing: He shall be brought unto the priest:

Numbers 6:13

And this is the law of the Nazarite, when the days of his separation are fulfilled: he shall be brought unto the door of the tabernacle of the congregation:

Numbers 5:29

This is the law of jealousies, when a wife goeth aside to another instead of her husband and is defiled;

Line 2469:

(2684) **ἐὰν**

Line 2470:

(2685) **δὲ**

Line 2471:

(2686) **ἀποθάνῃ**

Line 2472:

(2687) **ὁ**

Line 2473:

(2688) **ἀνὴρ,**

Line 2474:

(2689) **κατήργηται**

Line 2475:

(2690) **ἀπὸ**

Line 2476:

(2691) **τοῦ**

Line 2477:

(2692) **νόμου**

Line 2478:

(2693) **τοῦ**

Line 2479:

(2694) **ἀνδρός.**

Line 2480:

(2695) ἄρα

Line 2481:

(2696) οὖν

Line 2482:

(2697) ζῶντος

Line 2483:

(2698) τοῦ

Line 2484:

(2699) ἀνδρὸς

Line 2485:

(2700) μοιχαλὶς

Line 2486:

(2701) χρηματίσει,

Line 2487:

(2702) εἰάν

Line 2488:

(2703) γένηται

Line 2489:

(2704) ἀνδρὶ

Line 2490:

(2705) ἑτέρῳ·

γίγνεσθαι ἀνδρί

only applied to marriage

Leviticus 22:12-13

If the priest's daughter also be married unto a stranger, she may not eat of an offering of the holy things.

But if the priest's daughter be a widow, or divorced, and have no child, and is returned unto her father's house, as in her youth, she shall eat of her father's meat: but there shall be no stranger eat thereof.

Ruth 1:12

Turn again, my daughters, go your way; for I am too old to have an husband. If I should say, I have hope, if I should have an husband also to night, and should also bear sons;

Line 2480:

(2695) ἄρα

Line 2481:

(2696) οὖν

Line 2482:

(2697) ζῶντος

Line 2483:

(2698) τοῦ

Line 2484:

(2699) ἀνδρὸς

Line 2485:

(2700) μοιχαλὶς

Line 2486:

(2701) χρηματίσει,

Line 2487:

(2702) εἰάν

Line 2488:

(2703) γένηται

Line 2489:

(2704) ἀνδρὶ

Line 2490:

(2705) ἑτέρῳ·

Line 2491:

(2706) εἰάν

Line 2492:

(2707) δὲ

Line 2493:

(2708) ἀποθάνη

Line 2494:

(2709) ὁ

Line 2495:

(2710) ἀνὴρ,

Line 2496:

(2711) ἐλευθέρα

Line 2497:

(2712) ἐστὶν

Line 2498:

(2713) ἀπὸ

Line 2499:

(2714) τοῦ

Line 2500:

(2715) νόμου,



Line 2501:

(2716) τοῦ

Line 2502:

(2717) μή

Line 2503:

(2718) εἶναι

Line 2504:

(2719) αὐτήν

Line 2505:

(2720) μοιχαλίδα,

Line 2506:

(2721) γενομένην

Line 2507:

(2722) ἀνδρὶ

Line 2508:

(2723) ἑτέρῳ.



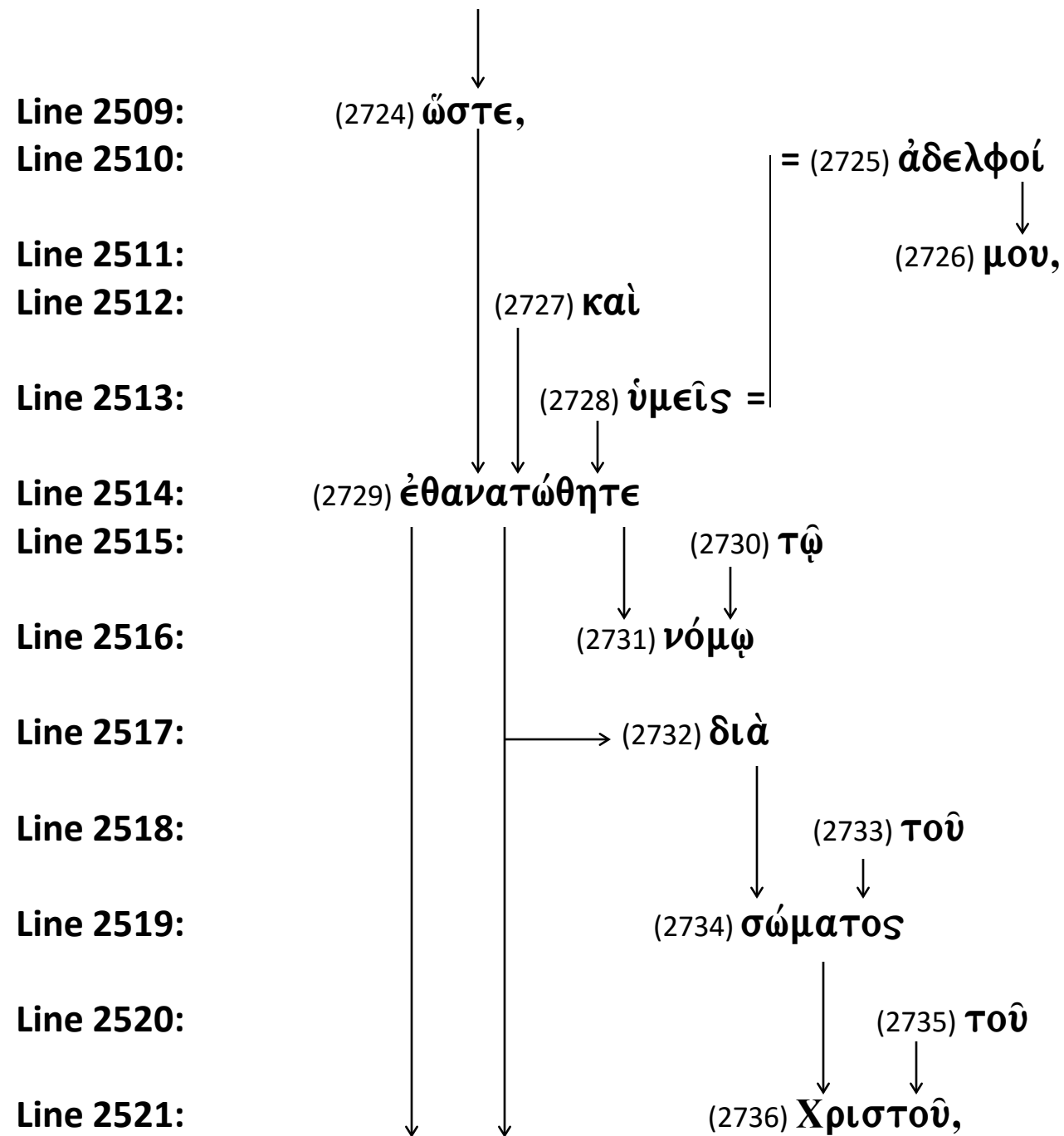

Line 2522:

(2737) εἰς

Line 2523:

(2738) τὸ

Line 2524:

(2739) γενέσθαι

Line 2525:

(2740) ὑμᾶς

Line 2526:

(2741) ἑτέρῳ, =

Line 2527:

= (2742) τῷ

Line 2528:

(2743) ἐκ (2744) νεκρῶν

Line 2529:

(2745) ἐγερθέντι,

Line 2530:

(2746) ἵνα

Line 2531:

(2747) καρποφορήσωμεν

Line 2532:

(2748) τῷ

Line 2533:

(2749) Θεῷ.



Line 2534:

(2750) ὅτε

Line 2535:

(2751) γὰρ

Line 2536:

(2752) ἡμεν

Line 2537:

(2753) ἐν

Line 2538:

(2754) τῇ

Line 2539:

(2755) σαρκί,

Line 2540:

(2756) τὰ

Line 2541:

(2757) παθήματα

Line 2542:

(2758) τῶν

Line 2543:

(2759) ἀμαρτιῶν

Line 2544:

(2760) τὰ

Line 2545:

(2761) διὰ

Line 2546:

(2762) τοῦ

Line 2547:

(2763) νόμου

"In the flesh"

Flesh not in physical but ethical quality as opposed to "spirit."

Same as "the old man" and "when we were in the body of sin" in Romans 6:6.

"Fleshly" or "of flesh"

Romans 7:14

For we know that the law is spiritual: but I am carnal, sold under sin.

Here Paul does not say he is still "in the flesh" but refers to the physical not ethical.

Line 2534:

(2750) ὅτε

Line 2535:

(2751) γὰρ

Line 2536:

(2752) ἡμεν

Line 2537:

(2753) ἐν

Line 2538:

(2754) τῇ

Line 2539:

(2755) σαρκί,

Line 2540:

(2756) τὰ

Line 2541:

(2757) παθήματα

Line 2542:

(2758) τῶν

Line 2543:

(2759) ἀμαρτιῶν

Line 2544:

(2760) τὰ

Line 2545:

(2761) διὰ

Line 2546:

(2762) τοῦ

Line 2547:

(2763) νόμου

Affections

Same as Galatians 5:24

Galatians 5:24

And they that are Christ's have crucified the flesh with the affections and lusts.

Line 2534:

(2750) ὅτε

Line 2535:

(2751) γὰρ

Line 2536:

(2752) ἡμεν

Line 2537:

(2753) ἐν

Line 2538:

(2754) τῇ

Line 2539:

(2755) σαρκί,

Line 2540:

(2756) τὰ

Line 2541:

(2757) παθήματα

Line 2542:

(2758) τῶν

Line 2543:

(2759) ἀμαρτιῶν

Line 2544:

(2760) τὰ

Line 2545:

(2761) διὰ

Line 2546:

(2762) τοῦ

Line 2547:

(2763) νόμου

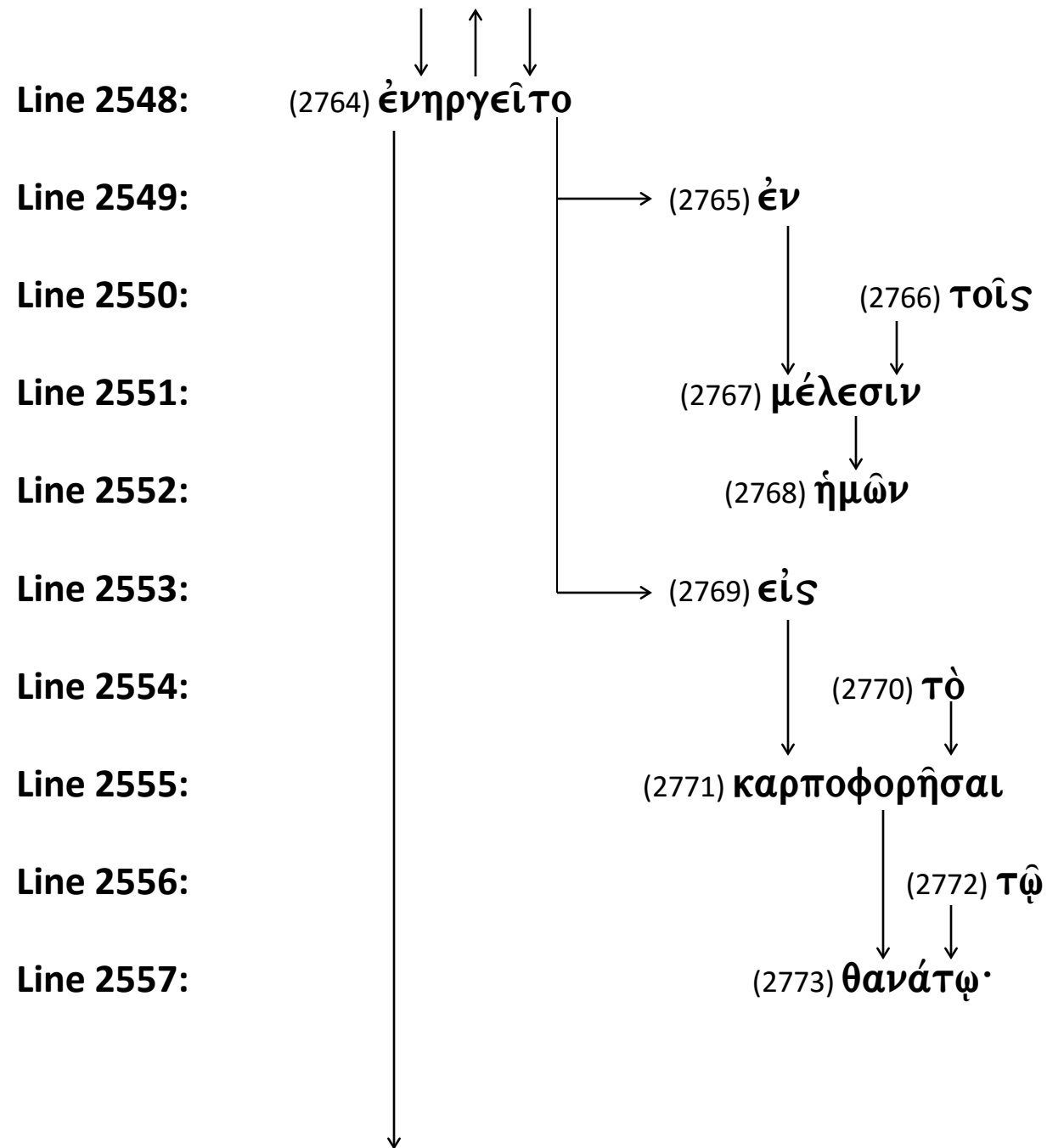

ἐνεργέω

From which the energy or active ἦθος is formed
ἦθος = a settled habit of mind and manners.

From ἔθος = a custom or usage.

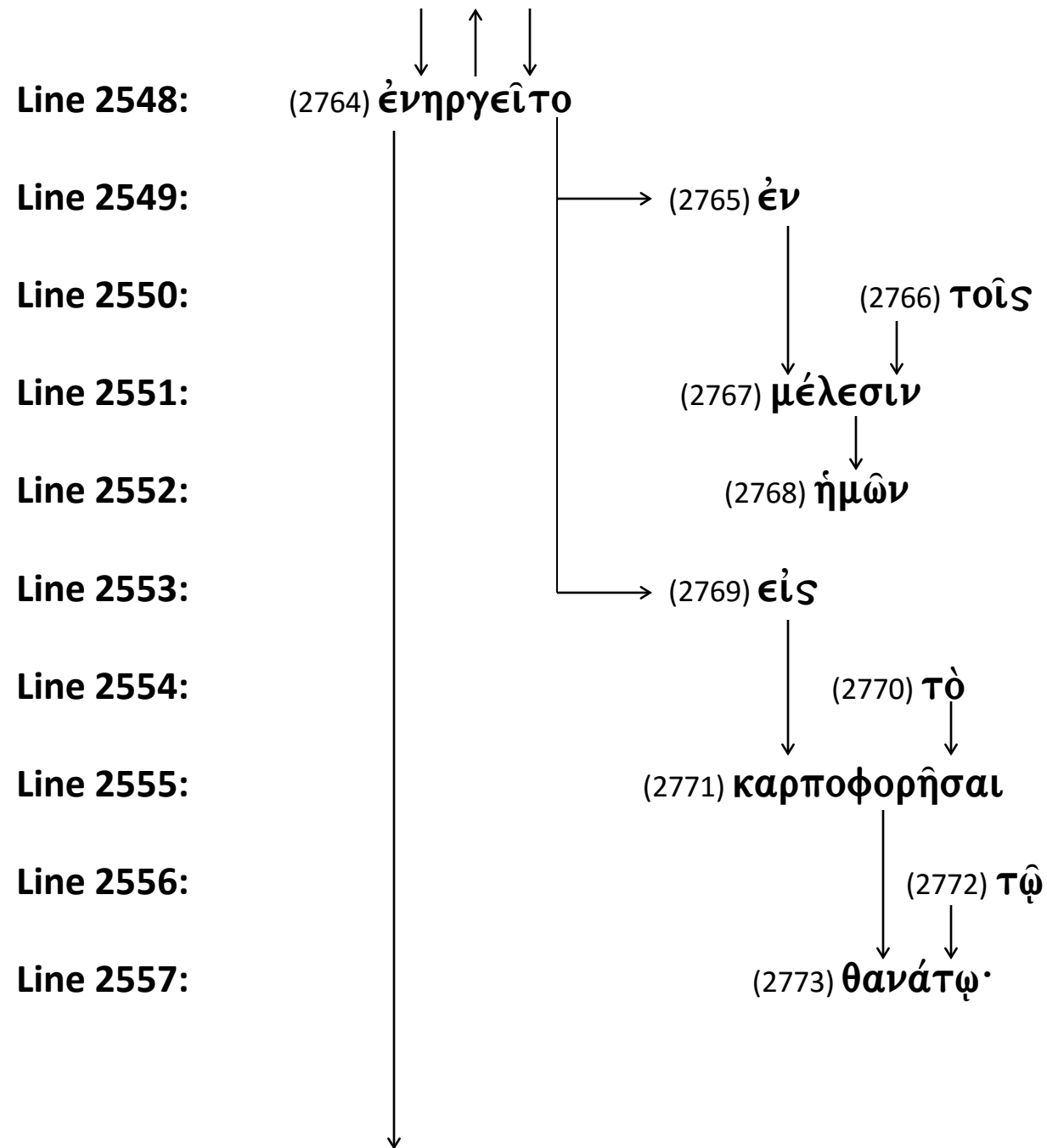

Line 2558:

(2774) **νυνὶ**

Line 2559:

(2775) **δὲ**

Line 2560:

(2776) **κατηργήθημεν**

Line 2561:

(2777) **ἀπὸ**

Line 2562:

(2778) **τοῦ**

Line 2563:

(2779) **νόμου,**

Line 2564:

(2780) **ἀποθανόντες**

Line 2565:

(2781) **ἐν**(2782) **ᾧ**

Line 2566:

(2783) **κατειχόμεθα,**



Line 2567:

(2784) ὥστε



Line 2568:

(2785) δουλεύειν



Line 2569:

(2786) ἡμᾶς



Line 2570:

(2787) ἐν



Line 2571:

(2788) καινότητι



Line 2572:

(2789) πνεύματος,



Line 2573:

(2790) καὶ



Line 2574:

(2791) οὐ



Line 2575:

(2792) παλαιότητι



Line 2576:

(2793) γράμματος.

New Testament

ROMANS

Greek Exegesis