

Lesson Thirty-Nine

Romans 9:19-29

19) Ἐρεῖς οὖν μοι, (οὖν) τί ἔτι μέμφεται; τῷ γὰρ
 You will say therefore to me, (therefore) Why still has He found fault? the for

βουλήματι αὐτοῦ τίς ἀνθέστηκε(ν);
 purpose of Him who has resisted?

20) (ὦ ἄνθρωπε) μενούγγε ὦ ἄνθρωπε σὺ τίς εἶ ὁ
 (O man) therefore indeed, O man, yourself who you are the one

ἀνταποκρινόμενος τῷ Θεῷ; μὴ ἐρεῖ τὸ πλάσμα τῷ
 answering against the God? not will say the thing formed the one

πλάσαντι, τί με ἐποίησας οὕτως;
 to having formed, Why me have you made this way?

21) ἢ οὐκ ἔχει ἐξουσίαν ὁ κεραμεὺς τοῦ πηλοῦ, ἐκ τοῦ αὐτοῦ
 or not does have authority the Potter the of clay, out of the same

φυράματος ποιῆσαι ὃ μὲν εἰς τιμὴν σκεύος, ὃ
 lump to make what on the one hand for honor vessel, what

δὲ εἰς ἀτιμίαν;
 on the other hand for dishonor?

22) εἰ δὲ θέλων ὁ Θεὸς ἐνδείξασθαι τὴν ὀργὴν, καὶ γνωρίσαι τὸ
 if and willing the God to demonstrate the wrath, and to make known the

δυνατὸν αὐτοῦ, ἤνεγκεν ἐν πολλῇ μακροθυμίᾳ σκεύη ὀργῆς
 power of Him, bore in much longsuffering vessels of wrath

κατηρτισμένα εἰς ἀπώλειαν·
 having been fitted for destruction;

23) καὶ ἵνα γνωρίσῃ τὸν πλοῦτον τῆς δόξης αὐτοῦ
 and in order that He might make known the wealth the of glory of Him

ἐπὶ σκεύη ἐλέους, ἃ προητοίμασεν εἰς δόξαν,
 upon vessels of mercy, which He prepared for glory,

24) οὓς καὶ ἐκάλεσεν ἡμᾶς οὐ μόνον ἐξ Ἰουδαίων, ἀλλὰ καὶ ἐξ
 which also He called us not only out of Jews, but also out of

ἐθνῶν;
 Gentiles?

- 25) ὡς καὶ ἐν τῷ Ὡσηὲ λέγει, Καλέσω τὸν οὐ λαὸν μου λαόν
as also in the Hosea He says, I will call the not people of Me people
μου· καὶ τὴν οὐκ ἠγαπημένην ἠγαπημένην.
of Me; and the not having been loved having been loved.
- 26) καὶ ἔσται, ἐν τῷ τόπῳ οὗ ἐρρήθη (ἐρρέθη) αὐτοῖς, Οὐ
and it will be, in the place where it was said (it was said) to them, Not
λαός μου ὑμεῖς, ἐκεῖ κληθήσονται υἱοὶ Θεοῦ ζῶντος.
people of me you, there they will be called sons of God living.
- 27) Ἡσαΐας δὲ κράζει ὑπὲρ τοῦ Ἰσραήλ, Ἐὰν ἦ ὁ ἀριθμὸς
Isaiah and cries out on behalf of the Israel, If should be the number
τῶν υἱῶν Ἰσραήλ ὡς ἡ ἄμμος τῆς θαλάσσης, τὸ κατάλειμμα
the of sons of Israel as the sand the of sea, the remnant
(ὑπόλειμμα) σωθήσεται·
(remnant) will be saved;
- 28) λόγον γὰρ συντελῶν καὶ συντέμνων [ἐν δικαιοσύνῃ· ὅτι λόγον
matter for concluding and cutting short [in righteousness; because matter
συντετμημένον] ποιήσει Κύριος ἐπὶ τῆς γῆς.
having been cut short] will do Lord upon the earth.
- 29) καὶ καθὼς προείρηκεν Ἡσαΐας, Εἰ μὴ Κύριος Σαβαὼθ
and according as has said before Isaiah, If not Lord of Sabaoth
ἐγκατέλιπεν ἡμῖν σπέρμα, ὡς Σόδομα ἂν ἐγενήθημεν, καὶ ὡς
had left to us seed, as Sodom would we have become, and as
Γόμορρα ἂν ὁμοιώθημεν.
Gomorra would we have been like.

Word Association Diagram

Romans 9:19-29

Verse 19

Line 3785:

(4085) Ἐρεῖς

Line 3786:

(4086) οὖν

Line 3787:

(4087) μοι,

Line 3788:

((4088) οὖν)

Line 3789:

(4089) τί

Line 3790:

(4090) ἔτι

Line 3791:

(4091) μέμφεται;

Line 3792:

(4092) τῷ

Line 3793:

(4093) γάρ

Line 3794:

(4094) βουλήματι

Line 3795:

(4095) αὐτοῦ

Line 3796:

(4096) τίς

Line 3797:

(4097) ἀνθέστηκε(ν);

Verse 20

Line 3798:

((4098) ὦ (4099) ἄνθρωπε)

Line 3799:

(4100) μενοῦνγε

Line 3800:

(4101) ὦ (4102) ἄνθρωπε

Line 3801:

(4103) σὺ =

Line 3802:

(4104) τίς

Line 3803:

(4105) εἶ

Line 3804:

(4106) ὁ

Line 3805:

= (4107) ἀνταποκρινόμενος

Line 3806:

(4108) τῷ

Line 3807:

(4109) Θεῷ;

Word Association Diagram

Romans 9:19-29

Verse 20 (cont.)

Line 3808:

(4110) μῆ

Line 3809:

(4111) ἔρεϊ

Line 3810:

(4112) τὸ

Line 3811:

(4113) πλάσμα

Line 3812:

(4114) τῷ

Line 3813:

(4115) πλάσαντι,

Line 3814:

(4116) τί

Line 3815:

(4117) με

Line 3816:

(4118) ἐποίησας

Line 3817:

(4119) οὕτως;

Verse 21

Line 3818:

(4120) ἦ

Line 3819:

(4121) οὐκ

Line 3820:

(4122) ἔχει

Line 3821:

(4123) ἐξουσίαν

Line 3822:

(4124) ὁ

Line 3823:

(4125) κεραμεύς

Line 3824:

(4126) τοῦ

Line 3825:

(4127) πηλοῦ,

Line 3826:

(4128) ἐκ

Line 3827:

(4129) τοῦ

Line 3828:

(4130) αὐτοῦ

Line 3829:

(4131) φυράματος

Line 3830:

(4132) ποιῆσαι

Word Association Diagram

Romans 9:19-29

Verse 21 (cont.)

Line 3831:

Line 3832:

Line 3833:

Line 3834:

Line 3835:

Line 3836:

Line 3837:

Verse 22

Line 3838:

Line 3839:

Line 3840:

Line 3841:

Line 3842:

Line 3843:

Line 3844:

Line 3845:

Line 3846:

Line 3847:

Line 3848:

Line 3849:

Line 3850:

Line 3851:

Line 3852:

Line 3853:

Line 3854:

Line 3855:

Line 3856:

Line 3857:

Line 3858:

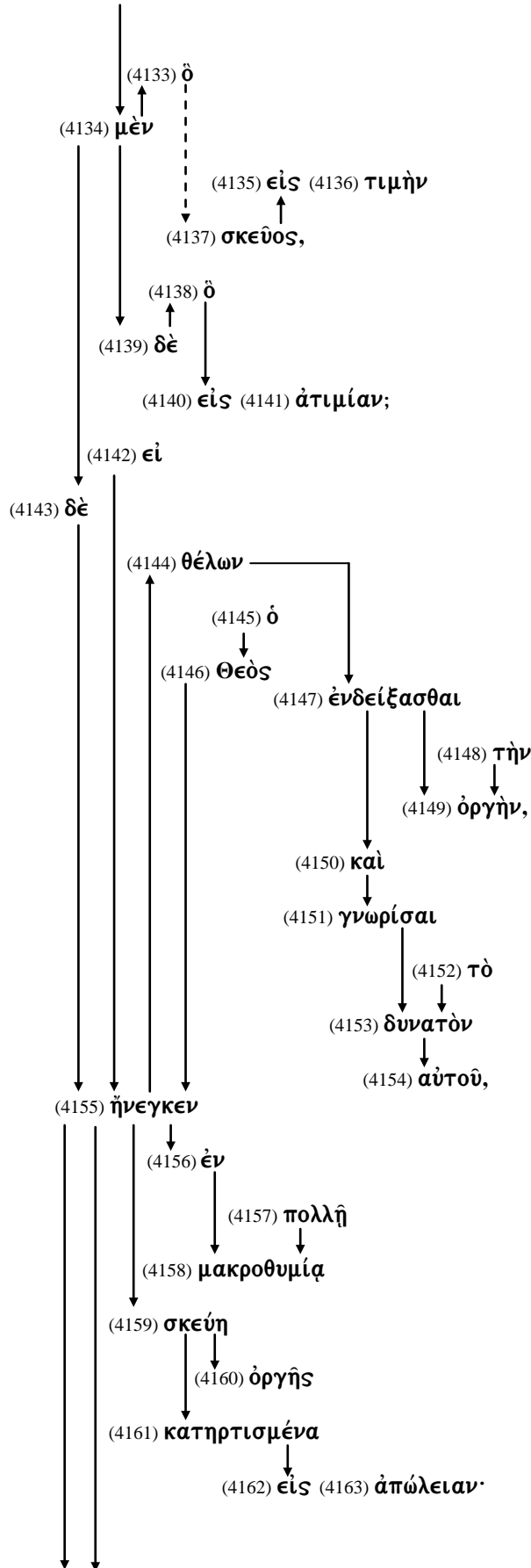

Word Association Diagram

Romans 9:19-29

Verse 23

Line 3859:

Line 3860:

Line 3861:

Line 3862:

Line 3863:

Line 3864:

Line 3865:

Line 3866:

Line 3867:

Line 3868:

Line 3869:

Line 3870:

Line 3871:

Verse 24

Line 3872:

Line 3873:

Line 3874:

Line 3875:

Line 3876:

Line 3877:

Line 3878:

Line 3879:

Line 3880:

Line 3881:

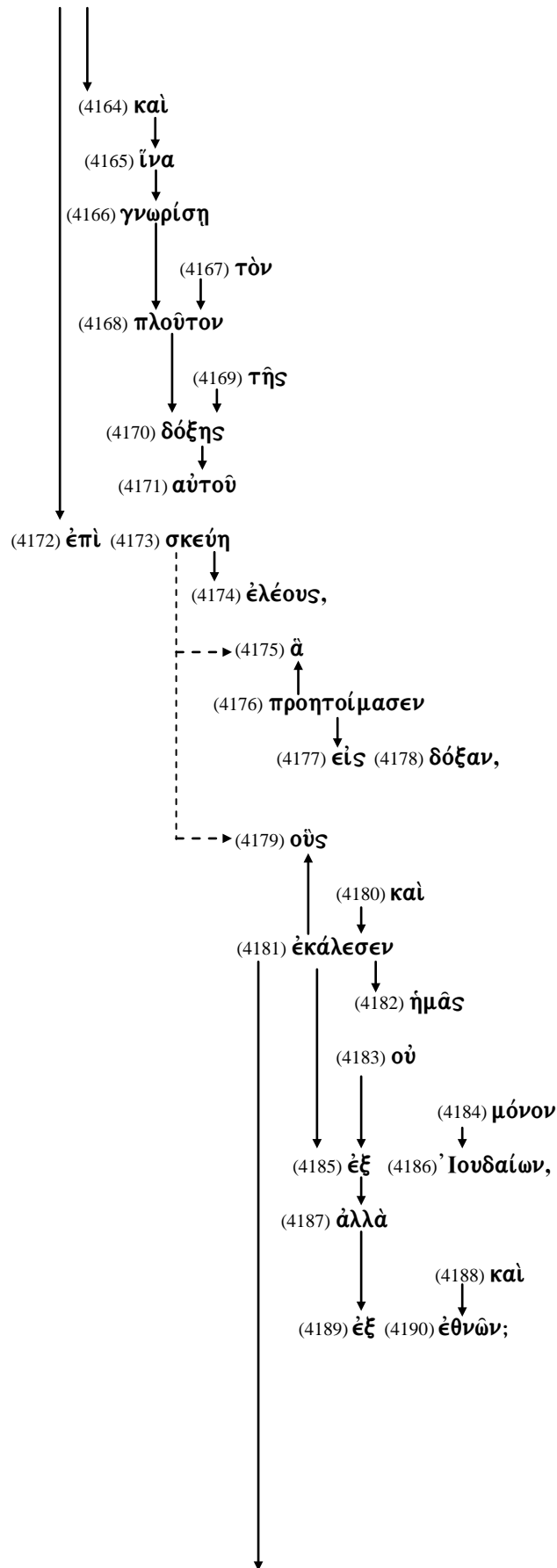

Word Association Diagram

Romans 9:19-29

Verse 25

Line 3882:

(4191) ὡς

Line 3883:

(4192) καὶ

Line 3884:

(4193) ἐν

Line 3885:

(4194) τῷ

Line 3886:

(4195) Ὡσηέ

Line 3887:

(4196) λέγει,

Line 3888:

(4197) Καλέσω

Line 3889:

(4198) τὸν

Line 3890:

(4199) οὐ

Line 3891:

(4200) λαόν

Line 3892:

(4201) μου

Line 3893:

(4202) λαόν

Line 3894:

(4203) μου·

Line 3895:

(4204) καὶ

Line 3896:

(4205) τὴν

Line 3897:

(4206) οὐκ

Line 3898:

(4207) ἠγαπημένην

Line 3899:

(4207) ἠγαπημένην.

Word Association Diagram

Romans 9:19-29

Verse 26

Line 3900:

Line 3901:

Line 3902:

Line 3903:

Line 3904:

Line 3905:

Line 3906:

Line 3907:

Line 3908:

Line 3909:

Line 3910:

Line 3911:

Line 3912:

Line 3913:

Line 3914:

Line 3915:

Line 3916:

Verse 27

Line 3917:

Line 3918:

Line 3919:

Line 3920:

Line 3921:

Line 3922:

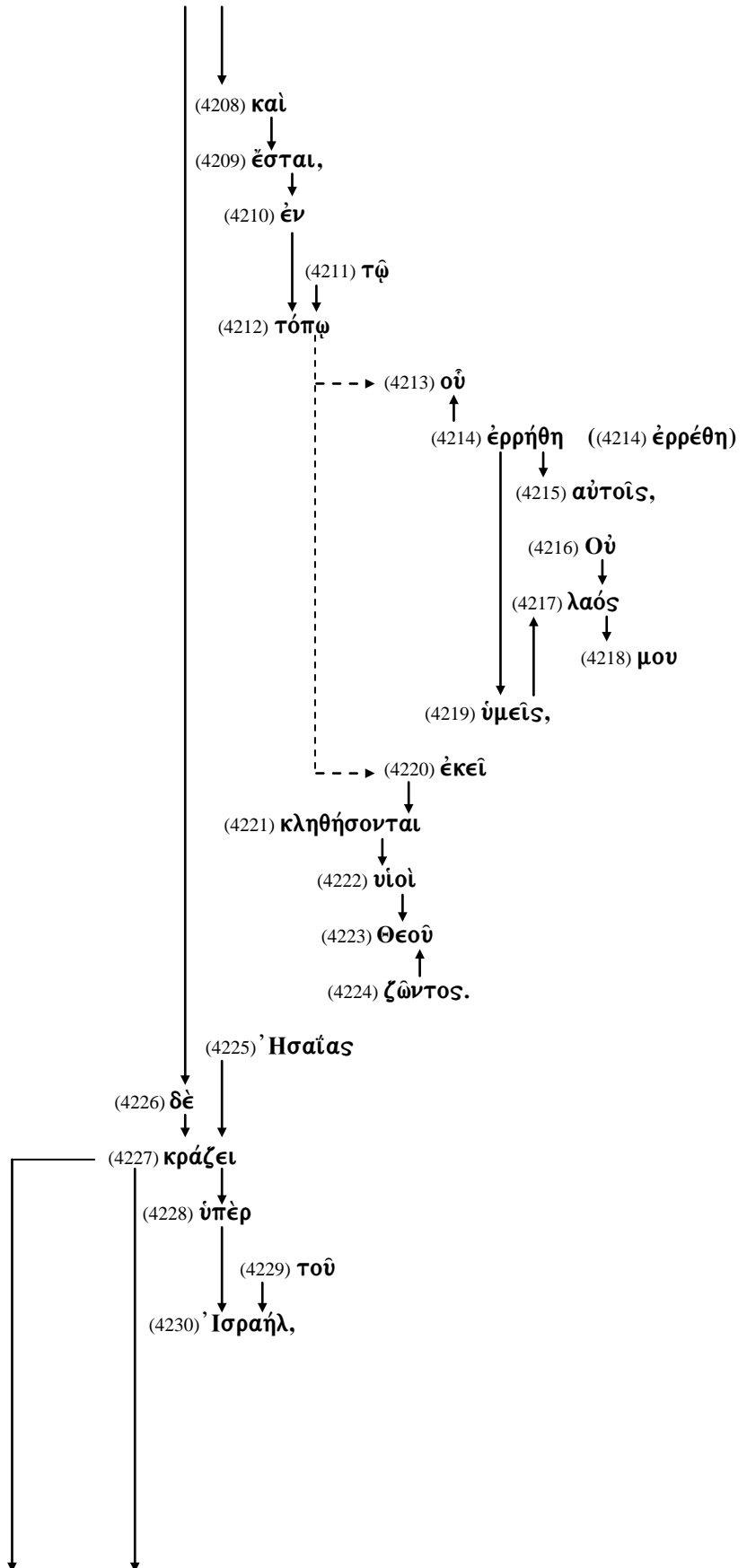

Word Association Diagram

Romans 9:19-29

Verse 27 (cont.)

Line 3923:

Line 3924:

Line 3925:

Line 3926:

Line 3927:

Line 3928:

Line 3929:

Line 3930:

Line 3931:

Line 3932:

Line 3933:

Line 3934:

Line 3935:

Line 3936:

Line 3937:

Verse 28

Line 3938:

Line 3939:

Line 3940:

Line 3941:

Line 3942:

Line 3943:

Line 3944:

Line 3945:

Line 3946:

Line 3947:

Line 3948:

Line 3949:

Line 3950:

Line 3951:

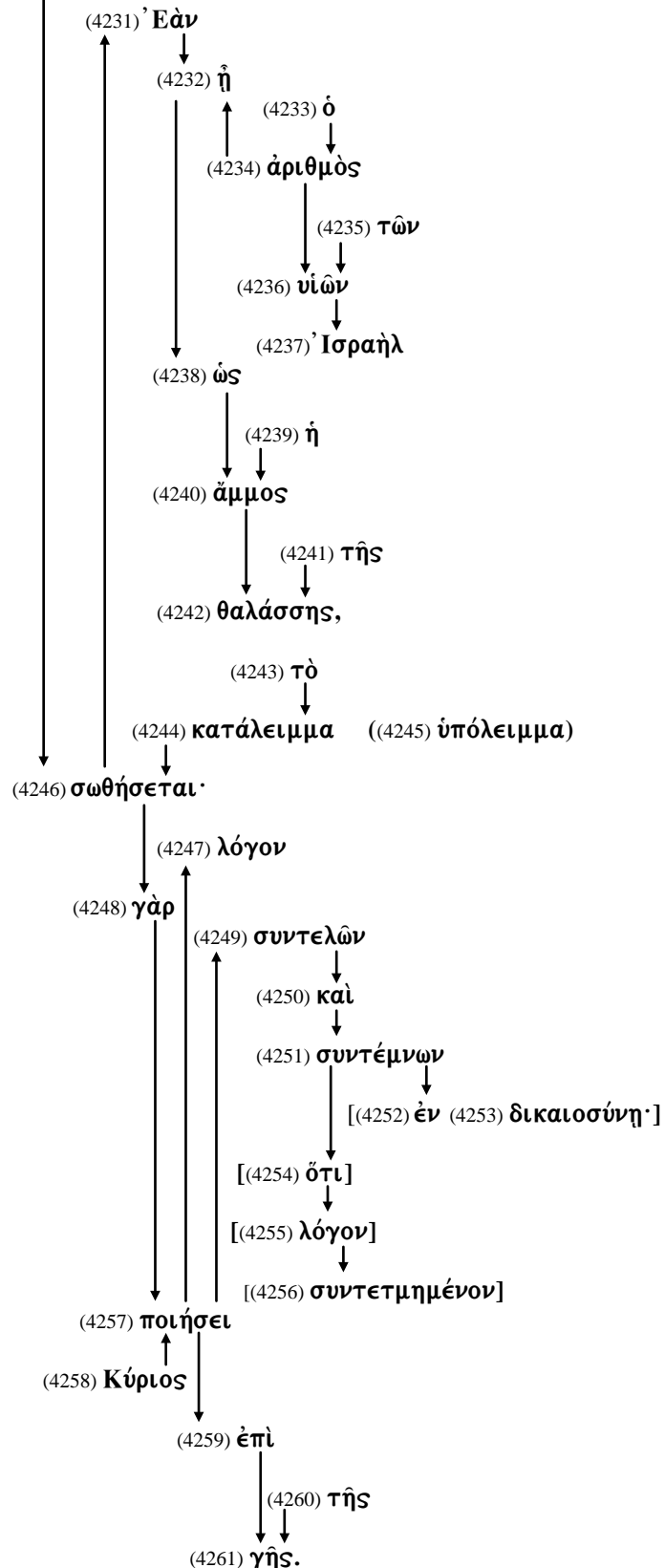

Word Association Diagram

Romans 9:19-29

Verse 29

Line 3952:

(4262) καὶ

Line 3953:

(4263) καθὼς

Line 3954:

(4264) προείρηκεν

Line 3955:

(4265) Ἡσαΐας,

Line 3956:

(4266) Εἰ (4267) μὴ

Line 3957:

(4268) Κύριος

Line 3958:

(4269) Σαβαώθ

Line 3959:

(4270) ἐγκατέλιπεν

Line 3960:

(4271) ἡμῖν

Line 3961:

(4272) σπέρμα,

Line 3962:

(4273) ὡς (4274) Σόδομα

Line 3963:

(4275) ἂν

Line 3964:

(4276) ἐγενήθημεν,

Line 3965:

(4277) καὶ

Line 3966:

(4278) ὡς (4279) Γόμορρα

Line 3967:

(4280) ἂν

Line 3968:

(4281) ὡμοιώθημεν.

Romans Outline

Chapters 1 - 9

I Romans 1:1-17

The Introduction

II Romans 1:18-11:36

The Doctrine of the Christian Faith

Romans 1:18-3:20

The Indictment: The Doctrine of Condemnation

Romans 3:21-5:21

The Imputation: The Doctrine of Justification

Romans 6:1-8:39

The Impartation: The Doctrine of Sanctification

Romans 9:1-11:36

The Inspiration: The Doctrine of Election

Romans 9 The Past History of Israel

Romans 9:1-13 The Plan of God

Romans 9:14-18 The Purpose of God

Romans 9:19-29 The Preparation of God

Romans 9:30-33 The People of God

Romans 10 The Present Condition of Israel

Romans 11 The Promise of the Future of Israel

Lesson Thirty-Nine

Romans 9:19-29

Diagrams

Romans 9:19 Diagram

Romans 9:19 Ἐρεῖς οὖν μοι, (οὖν) τί ἔτι μέμφεται; τῷ γὰρ βουλήματι αὐτοῦ τίς ἀνθέστηκε(ν);

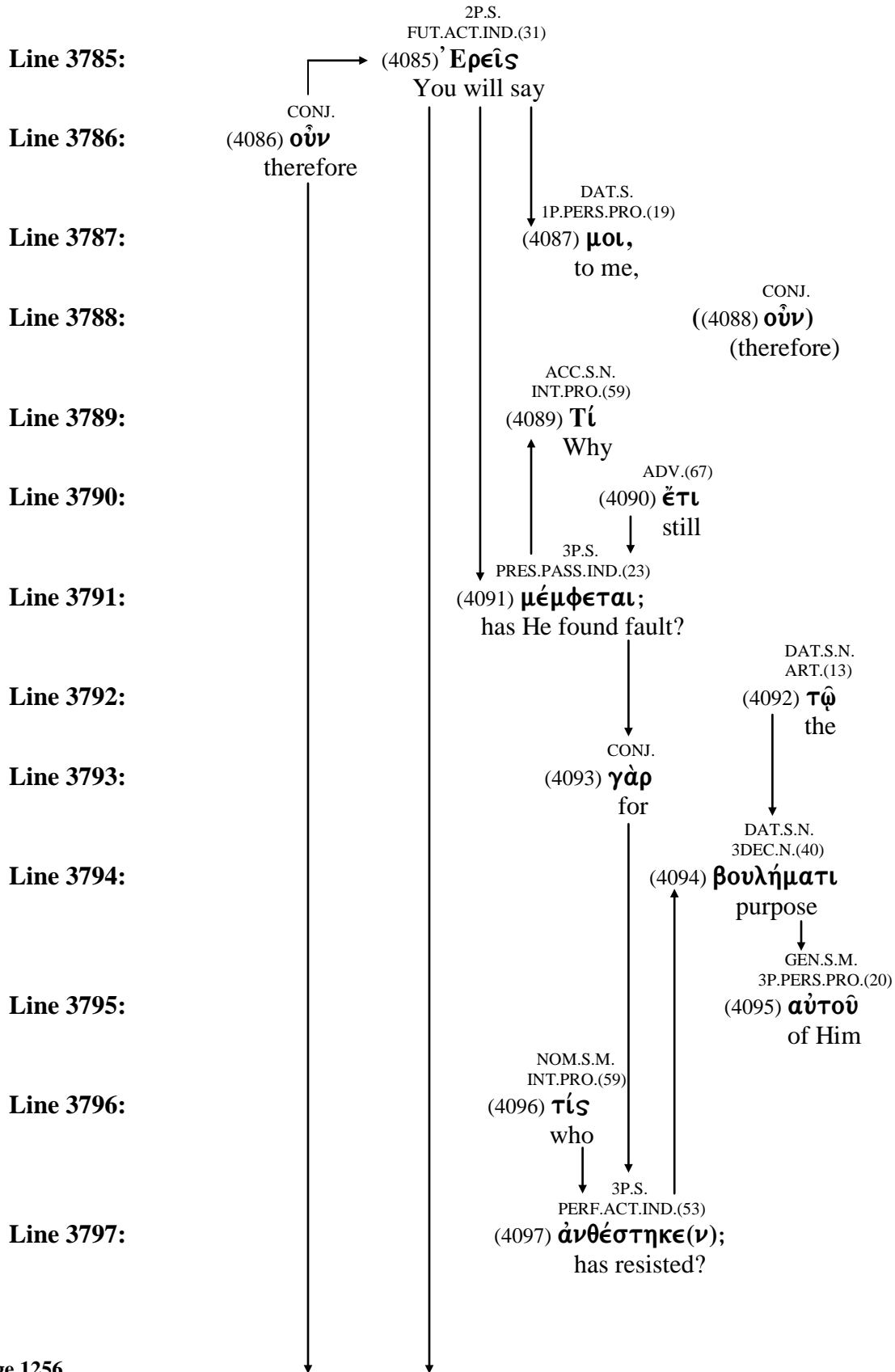

- (4085) **λέγω** = to say, to speak
- (4086) **οὖν** - particle = therefore, then
- (4087) **ἐγώ** - first person personal pronoun = I
- (4088) **οὖν** - particle = therefore, then
- (4089) **τίς** - interrogative pronoun = who, which, what
- (4090) **ἔτι** - adverb = yet, still
- (4091) **μέμφομαι** = to blame, to find fault
- (4092) **ὁ** - article = the
- (4093) **γάρ** - conjunction = for
- (4094) **βούλημα** = will, purpose, intention
from **βούλομαι** = to resolve, to purpose
- (4095) **αὐτός** - third person personal pronoun = he, she, it
- (4096) **τίς** - interrogative pronoun = who, which, what
- (4097) **ἀντίστημι** = to resist, to oppose
from **ἀντί** - preposition = to be against, to oppose, instead of
and **ἵστημι** = to stand

Romans 9:20 Diagram

Romans 9:20 (ὦ ἄνθρωπε) μενούγγε ὦ ἄνθρωπε σὺ τίς εἶ ὁ ἀνταποκρινόμενος τῷ Θεῷ; μὴ ἐρεῖ τὸ πλάσμα τῷ πλάσαντι, Τί με ἐποίησας οὕτως;

Line 3798:

INTERJECTION VOC.S.M.
2DEC.N.(12)
((4098) ὦ (4099) ἄνθρωπε)
(O man)

Line 3799:

PARTICLE
(4100) μενούγγε
therefore indeed,

Line 3800:

INTERJECTION VOC.S.M.
2DEC.N.(12)
(4101) ὦ (4102) ἄνθρωπε
O man

Line 3801:

NOM.S.
2P.PERS.PRO.(19)
(4103) σὺ =
yourself

Line 3802:

NOM.S.M.
INTR.PRO.(59)
(4104) τίς
who

Line 3803:

2P.S.
PRES.ACT.IND.(26)
(4105) εἶ
you are

Line 3804:

NOM.S.M.
ART.(13)
(4106) ὁ
the one

Line 3805:

NOM.S.M.
PRES.MID.PART.(42)
= (4107) ἀνταποκρινόμενος
answering against

Line 3806:

DAT.S.M.
ART.(13)
(4108) τῷ
the

Line 3807:

DAT.S.M.
2DEC.N.(12)
(4109) Θεῷ;
God?

- (4098) **ὦ** - interjection, a sign of the vocative = O
- (4099) **ἄνθρωπος** = a man, a human being
from **ἄνθρω** = a male
and **ψ** = the face or countenance
- (4100) **μενούργε** - particle = on the contrary, indeed, rather
from **μέν** - particle = indeed
and **ούν** - conjunction = therefore
and **γε** - particle of emphasis = at least, yet
- (4101) **ὦ** - interjection, a sign of the vocative = O
- (4102) **ἄνθρωπος** = a man, a human being
from **ἄνθρω** = a male
and **ψ** = the face or countenance
- (4103) **σύ** - second person personal pronoun = you
- (4104) **τίς** - interrogative pronoun = who, which, what
- (4105) **εἰμί** = to be, exist
- (4106) **ὁ** - article = the
- (4107) **ἀνταποκρίνομαι** = to answer back, to reply
from **ἀντί** - preposition = oppose, against
and **ἀποκρίνομαι** = to answer, to respond
from **ἀπό** - preposition = from
and **κρίνω** = to judge, to answer
- (4108) **ὁ** - article = the
- (4109) **θεός** = God, deity

Romans 9:20 Diagram

Romans 9:20 (ὦ ἄνθρωπε) μενοῦνγε ὦ ἄνθρωπε σὺ
 τίς εἶ ὁ ἀνταποκρινόμενος τῷ Θεῷ; μὴ ἐρεῖ τὸ
 πλάσμα τῷ πλάσαντι, Τί με ἐποίησας οὕτως;

Line 3808:

NEGATIVE
 PARTICLE
 (4110) **μὴ**
 not

Line 3809:

3P.S.
 FUT.ACT.IND.(31)
 (4111) **ἐρεῖ**
 will say

Line 3810:

DAT.S.N.
 ART.(13)
 (4112) **τὸ**
 the thing

Line 3811:

NOM.S.N.
 3DEC.N.(40)
 (4113) **πλάσμα**
 formed

Line 3812:

DAT.S.M.
 ART.(13)
 (4114) **τῷ**
 the one

Line 3813:

DAT.S.M.
 AOR.ACT.PART.(43)
 (4115) **πλάσαντι,**
 to having formed,

Line 3814:

ACC.S.N.
 INT.PRO.(59)
 (4116) **Τί**
 Why

Line 3815:

ACC.S.
 1P.PERS.PRO.(19)
 (4117) **με**
 me

Line 3816:

2P.S.
 2AOR.ACT.IND.(33)
 (4118) **ἐποίησας**
 have you made

Line 3817:

ADV.(67)
 (4119) **οὕτως;**
 this way?

- (4110) **μή** - negative particle = no, not
- (4111) **λέγω** = to say, to speak
- (4112) **ὁ** - article = the
- (4113) **πλάσμα** = something formed or molded
from **πλάσσω** = to form, to shape
- (4114) **ὁ** - article = the
- (4115) **πλάσσω** = to form, to shape
- (4116) **τίς** - interrogative pronoun = who, which, what
- (4117) **ἐγώ** - first person personal pronoun = I
- (4118) **ποιέω** = to make, to do
- (4119) **οὕτως** - adverb = so, thus, in this manner
from **οὗτος** - demonstrative pronoun = this

Romans 9:21 Diagram

Romans 9:21 ἡ οὐκ ἔχει ἐξουσίαν ὁ κεραμεὺς τοῦ πηλοῦ, ἐκ τοῦ αὐτοῦ φυράματος ποιῆσαι ὃ μὲν εἰς τιμὴν σκευῶς, ὃ δὲ εἰς ἀτιμίαν;

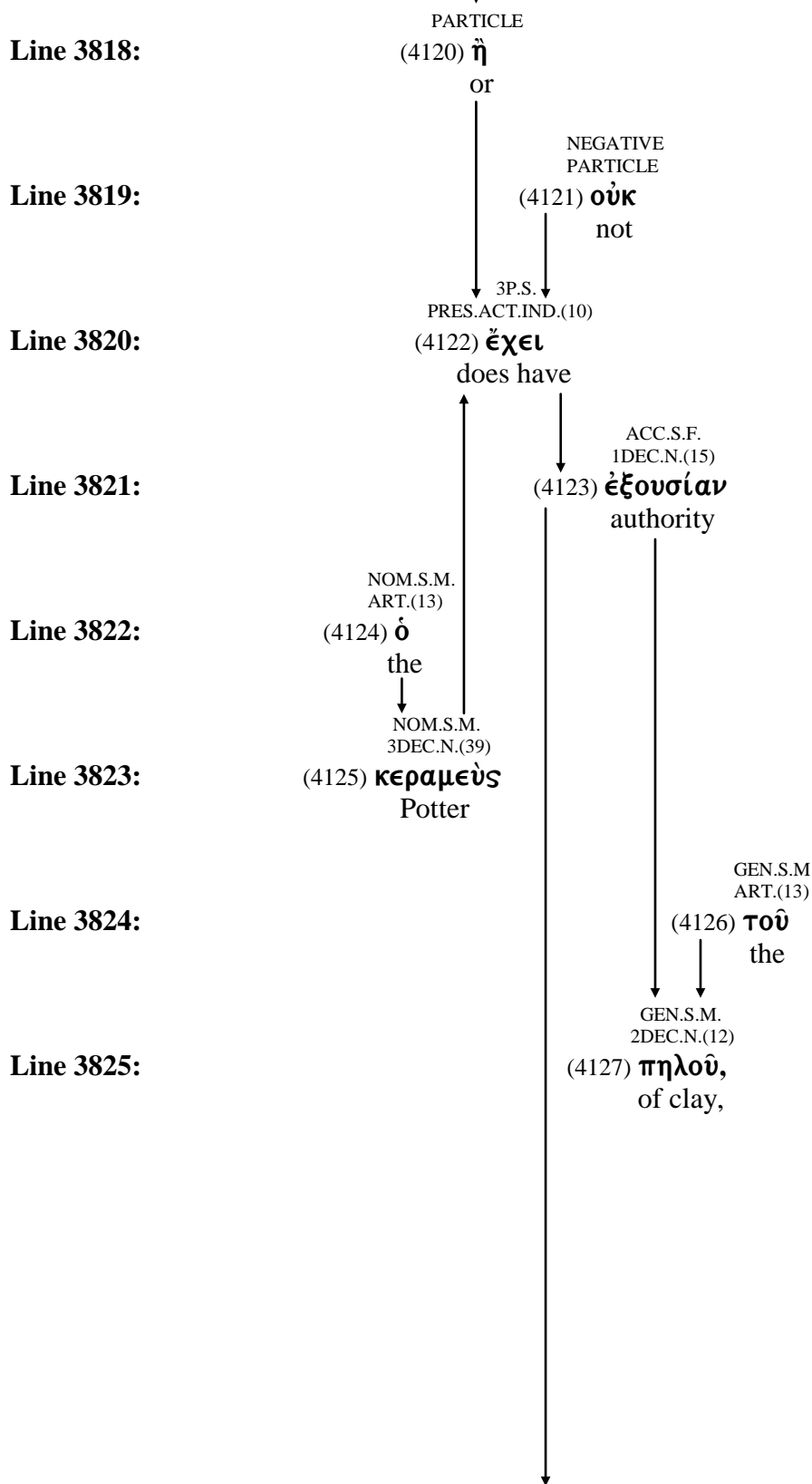

(4120) **ἢ** - particle used as a conjunction = or

(4121) **οὐ** - negative particle = no, not

(4122) **ἔχω** = to have, to hold

(4123) **ἐξουσία** = power, authority, right
from **ἔξεστι** = it is lawful
from **ἐκ** - preposition = from, out of
and **εἰμί** = to be, to exist

(4124) **ὁ** - article = the

(4125) **κεραμεύς** = a potter
from **κεραμεύς** = earthenware, tile, roofing

(4126) **ὁ** - article = the

(4127) **πηλός** = clay, dust, soil

Romans 9:21 Diagram

Romans 9:21 ἡ οὐκ ἔχει ἐξουσίαν ὁ κεραμεὺς τοῦ πηλοῦ, ἐκ τοῦ αὐτοῦ φυράματος ποιῆσαι ὃ μὲν εἰς τιμὴν σκεῦος, ὃ δὲ εἰς ἀτιμίαν;

Line 3826:

PREP.
W/GEN.(18)
(4128) **ἐκ**
out of

Line 3827:

GEN.S.N.
ART.(13)
(4129) **τοῦ**
the
GEN.S.N.
3PERS.PRO.(20)
(4130) **αὐτοῦ**
same

Line 3828:

GEN.S.N.
3DEC.N.(40)
(4131) **φυράματος**
lump

Line 3829:

AOR.ACT.INF.(50)
(4132) **ποιῆσαι**
to make

Line 3830:

Line 3831:

ACC.S.N.
REL.PRO.(62)
(4133) **ὃ**
what

Line 3832:

PARTICLE
(4134) **μὲν**
on the one hand

Line 3833:

PREP.
W/ACC.(18) ACC.S.F.
1DEC.N.(14)
(4135) **εἰς** (4136) **τιμὴν**
for honor

Line 3834:

ACC.S.N.
3DEC.N.(39)
(4137) **σκεῦος,**
vessel,

Line 3835:

ACC.S.N.
REL.PRO.(62)
(4138) **ὃ**
what

Line 3836:

CONJ.
(4139) **δὲ**
on the other hand

Line 3837:

PREP.
W/ACC.(18) ACC.S.F.
1DEC.N.(15)
(4140) **εἰς** (4141) **ἀτιμίαν;**
for dishonor?

- (4128) **ἐκ** - preposition used with the genitive = out of, from
- (4129) **ὁ** - article = the
- (4130) **αὐτός** - third person personal pronoun = he, she, it
- (4131) **φύραμα** = a lump of clay
from **φύρω** = to mix, to knead a mass of dough
- (4132) **ποιέω** = to make, to do
- (4133) **ὅς** - relative pronoun = who, which, what
- (4134) **μέν** - particle = truly, certainly, indeed
- (4135) **εἰς** - preposition used with the accusative = to, unto, towards
- (4136) **τιμή** = honor, price, value
- (4137) **σκεῦος** = a vessel, a utensil
- (4138) **ὅς** - relative pronoun = who, which, what
- (4139) **δὲ** - conjunction = and, now, even
- (4140) **εἰς** - preposition used with the accusative = to, unto, towards
- (4141) **ἀτιμία** = dishonor, disgrace, shame
from **ἄτιμος** - adjective = dishonorable
from **α** - used as a negative particle
and **τιμή** = honor, value

Romans 9:22 Diagram

Romans 9:22 εἰ δὲ θέλων ὁ Θεὸς ἐνδείξασθαι τὴν ὀργὴν, καὶ γνωρίσαι τὸ δυνατὸν αὐτοῦ, ἤνεγκεν ἐν πολλῇ μακροθυμίᾳ σκευὴ ὀργῆς κατηρτισμένα εἰς ἀπώλειαν·

Line 3838:

CONJ.
(4142) εἰ
if

Line 3839:

CONJ.
(4143) δὲ
and

Line 3840:

NOM.S.M.
PRES.ACT.PART.(42)
(4144) θέλων
willing

Line 3841:

NOM.S.M.
ART.(13)
(4145) ὁ
the

Line 3842:

NOM.S.M.
ART.(13)
(4146) Θεὸς
God

Line 3843:

AOR.MID.INF.(50)
(4147) ἐνδείξασθαι
to demonstrate

Line 3844:

ACC.S.F.
ART.(13)
(4148) τὴν
the

Line 3845:

ACC.S.F.
1DEC.N.(14)
(4149) ὀργὴν,
wrath,

Line 3846:

CONJ.
(4150) καὶ
and

Line 3847:

AOR.ACT.INF.(50)
(4151) γνωρίσαι
to make known

Line 3848:

ACC.S.N.
ART.(13)
(4152) τὸ
the

Line 3849:

ACC.S.N.
3D.ADJ.(56)
(4153) δυνατὸν
power

Line 3850:

GEN.S.M.
3P.PERS.PRO.(20)
(4154) αὐτοῦ,
of Him,

- (4142) **εἰ** - conjunction = if
- (4143) **δὲ** - conjunction = and, now, even
- (4144) **θέλω** = to will, intend, to desire
- (4145) **ὁ** - article = the
- (4146) **θεός** = God, deity
- (4147) **ἐνδείξασθαι** = to show, to point out, to demonstrate
from **ἐν** - preposition = in
and **δεικνύω** = to show, demonstrate
- (4148) **ὁ** - article = the
- (4149) **ὀργή** = anger, impulse; any violent expression of emotion
from **ὀρέγω** = to stretch or reach for something
- (4150) **καί** - conjunction = and, also, even
- (4151) **γνωρίζω** = to come to know, to make known
from **γινώσκω** = I know
- (4152) **ὁ** - article = the
- (4153) **δυνατός** = power, capability, might
from **δύναμαι** = to be able
- (4154) **αὐτός** - third person personal pronoun = he, she, it

Romans 9:22 Diagram

Romans 9:22 εἰ δὲ θέλων ὁ Θεὸς ἐνδείξασθαι τὴν ὀργὴν, καὶ γνωρίσαι τὸ δυνατὸν αὐτοῦ, ἤνεγκεν ἐν πολλῇ μακροθυμίᾳ σκεύη ὀργῆς κατηρτισμένα εἰς ἀπώλειαν·

Line 3851:

2AOR.ACT.IND.(35)
(4155) ἤνεγκεν

bore

Line 3852:

PREP.
W/DAT.(18)
(4156) ἐν

in

Line 3853:

DAT.S.F.
3D.ADJ.(56)
(4157) πολλῇ
much

Line 3854:

DAT.S.F.
1DEC.N.(15)
(4158) μακροθυμίᾳ
longsuffering

Line 3855:

ACC.PL.N.
3DEC.N.(39)
(4159) σκεύη
vessels

Line 3856:

GEN.S.F.
1DEC.N.(14)
(4160) ὀργῆς
of wrath

Line 3857:

ACC.PL.N.
PERF.PASS.PART.(55)
(4161) κατηρτισμένα
having been fitted

Line 3858:

PREP.
W/ACC.(18) ACC.S.F.
1DEC.N.(15)
(4162) εἰς (4163) ἀπώλειαν·
for destruction;

- (4155) **φέρω** = to carry, to bear, to bring
- (4156) **ἐν** - preposition used with the dative = in
- (4157) **πολύς** - adjective = many, much, large
- (4158) **μακροθυμία** = longsuffering, slow in human reaction towards someone
from **μακρός** - adjective = long, far
from **μῆκος** = length
and **θυμός** = heat, anger, passion
- (4159) **σκεῦος** = a vessel, a utensil
- (4160) **ὀργή** = anger, impulse; any violent expression of emotion
from **ὀρέγω** = to stretch or reach for something
- (4161) **καταρτίζω** = to mend, to make complete or sound
from **κατά** - preposition = according to, against; down
and **ἄρτιος** - adjective = fitted, complete, perfect
- (4162) **εἰς** - preposition used with the accusative = to, unto, towards
- (4163) **ἀπώλεια** = destruction
from **ἀπόλλυμι** = to destroy
from **ἀπό** - preposition = from
and **ὀλέθριος** = destruction of the flesh, death

Romans 9:23 Diagram

Romans 9:23 καὶ ἵνα γνωρίσῃ τὸν πλοῦτον τῆς δόξης αὐτοῦ ἐπὶ σκευὴ ἐλέους, ἃ προητοίμασεν εἰς δόξαν,

Line 3859:

CONJ.
(4164) καὶ
and

Line 3860:

CONJ.
(4165) ἵνα
in order that

Line 3861:

3P.S.
AOR.ACT.SUBJ.(48)
(4166) γνωρίσῃ
He might make known

Line 3862:

ACC.S.M.
ART.(13)
(4167) τὸν
the

Line 3863:

ACC.S.M.
2DEC.N.(12)
(4168) πλοῦτον
wealth

Line 3864:

GEN.S.F.
ART.(13)
(4169) τῆς
the

Line 3865:

GEN.S.F.
1DEC.N.(15)
(4170) δόξης
of glory

Line 3866:

GEN.S.M.
3P.PERS.PRO.(20)
(4171) αὐτοῦ
of Him

(4164) **καί** - conjunction = and, also, even

(4165) **ἵνα** - conjunction = that, in order that

(4166) **γνωρίζω** = to come to know, to make known
from **γινώσκω** = I know

(4167) **ὁ** - article = the

(4168) **πλοῦτος** = riches, wealth
from **πίμπλημι** = to fill

(4169) **ὁ** - article = the

(4170) **δόξα** = glory, honor; opinion, judgment, view
from **δοκέω** = to think, suppose, presume; to have an opinion of

(4171) **αὐτός** - third person personal pronoun = he, she, it

Romans 9:23 Diagram

Romans 9:23 καὶ ἵνα γνωρίση τὸν πλοῦτον τῆς δόξης αὐτοῦ ἐπὶ σκεύη ἐλέους, ἃ προητοίμασεν εἰς δόξαν,

Line 3867:

PREP. ACC.PL.N.
W/ACC.(18) 3DEC.N.(39)
(4172) ἐπὶ (4173) σκεύη
upon vessels

Line 3868:

GEN.S.N.
3DEC.N.(39)
(4174) ἐλέους,
of mercy,

Line 3869:

ACC.PL.N.
REL.PRO.(62)
(4175) ἃ
which

Line 3870:

3P.S.
AOR.ACT.IND.(33)
(4176) προητοίμασεν
He prepared

Line 3871:

PREP. ACC.S.F.
W/ACC.(18) 1DEC.N.(15)
(4177) εἰς (4178) δόξαν,
for glory,

(4172) **ἐπί** - preposition used with the accusative = on, to, against

(4173) **σκεῦος** = a vessel, a utensil

(4174) **ἔλεος** = mercy, pity

(4175) **ὅς** - relative pronoun = who, which, what

(4176) **προετοιμάζω** = to prepare before
from **πρό** - preposition = before, in front of
and **ἐτοιμάζω** = to prepare, to provide
from **ἔτοιμος** - adjective = ready, prepared

(4177) **εἰς** - preposition used with the accusative = to, unto, towards

(4178) **δόξα** = glory, honor; opinion, judgment, view
from **δοκέω** = to think, suppose, presume; to have an opinion of

Romans 9:24 Diagram

Romans 9:24 οὗς καὶ ἐκάλεσεν ἡμᾶς οὐ μόνον ἐξ Ἰουδαίων, ἀλλὰ καὶ ἐξ ἐθνῶν;

Line 3872:

ACC.PL.M.
REL.PRO.(62)

(4179) οὗς
which

Line 3873:

CONJ.
(4180) καὶ
also

Line 3874:

3P.S.
AOR.ACT.IND.(33)

(4181) ἐκάλεσεν
He called

Line 3875:

ACC.PL.
1P.PERS.PRO.(19)

(4182) ἡμᾶς
us

Line 3876:

NEGATIVE
PARTICLE

(4183) οὐ
not

Line 3877:

ADV.(67)

(4184) μόνον
only

Line 3878:

PREP.
W/GEN.(18)

(4185) ἐξ
out of

GEN.PL.M.
ADJ.(17)

(4186) Ἰουδαίων,
Jews,

Line 3879:

CONJ.

(4187) ἀλλὰ
but

Line 3880:

CONJ.

(4188) καὶ
also

Line 3881:

PREP.
W/GEN.(18)

(4189) ἐξ
out of

GEN.PL.N.
2DEC.N.(12)

(4190) ἐθνῶν;
Gentiles?

- (4179) **ὅς** - relative pronoun = who, which, what
- (4180) **καί** - conjunction = and, also, even
- (4181) **καλέω** = to call
from **κελεύω** = to command, to order
from **κέλλω** = to urge on
- (4182) **ἐγώ** - first person personal pronoun = I
- (4183) **οὐ** - negative particle = no, not
- (4184) **μόνον** - adverb = only
from **μόνος** - adjective = alone, only
from **μένω** = abide, remain
- (4185) **ἐκ** - preposition used with the genitive = out of, from
- (4186) **Ἰουδαίος** - adjective = Jewish, belonging to the Jewish race.
from **Ἰουδά** - Judah = "He shall be praised"
- (4187) **ἀλλά** - conjunction = but
- (4188) **καί** - conjunction = and, also, even
- (4189) **ἐκ** - preposition used with the genitive = out of, from
- (4190) **ἔθνος** = gentiles, a nation, a multitude
from **ἔθος** = custom, usage

Romans 9:25 Diagram

Romans 9:25 ὡς καὶ ἐν τῷ Ὡσηὲ λέγει, Καλέσω τὸν οὐ λαόν μου λαόν μου· καὶ τὴν οὐκ ἠγαπημένην ἠγαπημένην.

Line 3882:

PARTICLE
(4191) ὡς

as

Line 3883:

CONJ.
(4192) καὶ
also

Line 3884:

PREP.
W/DAT.(18)
(4193) ἐν
in

Line 3885:

DAT.S.M.
ART.(13)
(4194) τῷ
the

Line 3886:

DAT.S.M.
PROP.NM.(65)
(4195) Ὡσηὲ
Hosea

Line 3887:

3P.S.
PRES.ACT.IND.(10)
(4196) λέγει,
He says,

Line 3888:

IP.S.
FUT.ACT.IND.(31)
(4197) Καλέσω
I will call

Line 3889:

ACC.S.M.
ART.(13)
(4198) τὸν
the

Line 3890:

NEGATIVE
PARTICLE
(4199) οὐ
not

Line 3891:

ACC.S.M.
2DEC.N.(12)
(4200) λαόν
people

Line 3892:

GEN.S.
1P.PERS.PRO.(19)
(4201) μου
of Me

Line 3893:

ACC.S.M.
2DEC.N.(12)
(4202) λαόν
people

Line 3894:

GEN.S.
1P.PERS.PRO.(19)
(4203) μου·
of Me;

(4191) **ὡς** - adverb used as a comparative particle = as, like
from **ὅς** - relative pronoun = who, which, what

(4192) **καί** - conjunction = and, also, even

(4193) **ἐν** - preposition used with the dative = in

(4194) **ὁ** - article = the

(4195) **Ἡοσηέ** - proper name = Hosea

(4196) **λέγω** = to say, to speak

(4197) **καλέω** = to call
from **κελεύω** = to command, to order
from **κέλλω** = to urge on

(4198) **ὁ** - article = the

(4199) **οὐ** - negative particle = no, not

(4200) **λαός** = a people, tribe, nation

(4201) **ἐγώ** - first person personal pronoun = I

(4202) **λαός** = a people, tribe, nation

(4203) **ἐγώ** - first person personal pronoun = I

Romans 9:25 Diagram

Romans 9:25 ὡς καὶ ἐν τῷ Ὄση ἐλέγει, Καλέσω τὸν οὐ λαόν μου λαόν μου· καὶ τὴν οὐκ ἠγαπημένην ἠγαπημένην.

Line 3895:

CONJ.
(4204) καὶ
and

Line 3896:

ACC.S.F.
ART.(13)
(4205) τὴν
the

Line 3897:

NEGATIVE
PARTICLE
(4206) οὐκ
not

Line 3898:

ACC.S.F.
PERF.PASS.PART.(55)
(4207) ἠγαπημένην
having been loved

Line 3899:

ACC.S.F.
PERF.PASS.PART.(55)
(4207) ἠγαπημένην.
have been loved.

(4204) **καί** - conjunction = and, also, even

(4205) **ὁ** - article = the

(4206) **οὐ** - negative particle = no, not

(4207) **ἀγαπάω** = to love

Romans 9:26 Diagram

Romans 9:26 καὶ ἔσται, ἐν τῷ τόπῳ οὐ ἔρρηθη (ἔρρέθη) αὐτοῖς, Οὐ λαός μου ὑμεῖς, ἐκεῖ κληθήσονται υἱοὶ Θεοῦ ζῶντος.

Line 3900:

(4208) καὶ
and

Line 3901:

(4209) ἔσται,
it will be,

Line 3902:

(4210) ἐν
in

Line 3903:

(4211) τῷ
the

Line 3904:

(4212) τόπῳ
place

Line 3905:

(4213) οὐ
where

Line 3906:

(4214) ἔρρηθη (4214) ἔρρέθη
it was said (it was said)

Line 3907:

(4215) αὐτοῖς,
to them,

Line 3908:

(4216) Οὐ
Not

Line 3909:

(4217) λαός
people

Line 3910:

(4218) μου
of me

Line 3911:

(4219) ὑμεῖς,
you,

- (4208) **καί** - conjunction = and, also, even
- (4209) **εἰμί** = to be, exist
- (4210) **ἐν** - preposition used with the dative = in
- (4211) **ὁ** - article = the
- (4212) **τόπος** = place, location
- (4213) **ὅς** - relative pronoun = who, which, what
- (4214) **ῥέω** = to flow, speech
- (4215) **αὐτός** - third person personal pronoun = he, she, it
- (4216) **οὐ** - negative particle = no, not
- (4217) **λαός** = a people, tribe, nation
- (4218) **ἐγώ** - first person personal pronoun = I
- (4219) **σύ** - second person personal pronoun = you

Romans 9:26 Diagram

Romans 9:26 καὶ ἔσται, ἐν τῷ τόπῳ οὗ ἐρρήθη
(ἐρρέθη) αὐτοῖς, Οὐ λαός μου ὑμεῖς, ἐκεῖ
κληθήσονται υἱοὶ Θεοῦ ζῶντος.

Line 3912:

ADV.(67)
-----> (4220) ἐκεῖ
there

Line 3913:

3P.PL.
FUT.PASS.IND.(38)
(4221) κληθήσονται
they will be called

Line 3914:

NOM.PL.M.
2DEC.N.(12)
(4222) υἱοὶ
sons

Line 3915:

GEN.S.M.
2DEC.N.(12)
(4223) Θεοῦ
of God

Line 3916:

GEN.S.M.
PRES.ACT.PART.(41)
(4224) ζῶντος.
living.

(4220) **ἐκεῖ** - adverb = there, in that place

(4221) **καλέω** = to call
from **κελεύω** = to command, to order
from **κέλλω** = to urge on

(4222) **υἱός** = son, descendant

(4223) **θεός** = God, deity

(4224) **ζωή** = life
from **ζάω** = to live, to breathe

Romans 9:27 Ἡσαΐας δὲ κράζει ὑπὲρ τοῦ Ἰσραήλ,
 Ἐὰν ᾗ ὁ ἀριθμὸς τῶν υἱῶν Ἰσραὴλ ὡς ἡ ἄμμος τῆς
 θαλάσσης, τὸ κατάλειμμα (ὑπόλειμμα) σωθήσεται.

Romans 9:27 Diagram

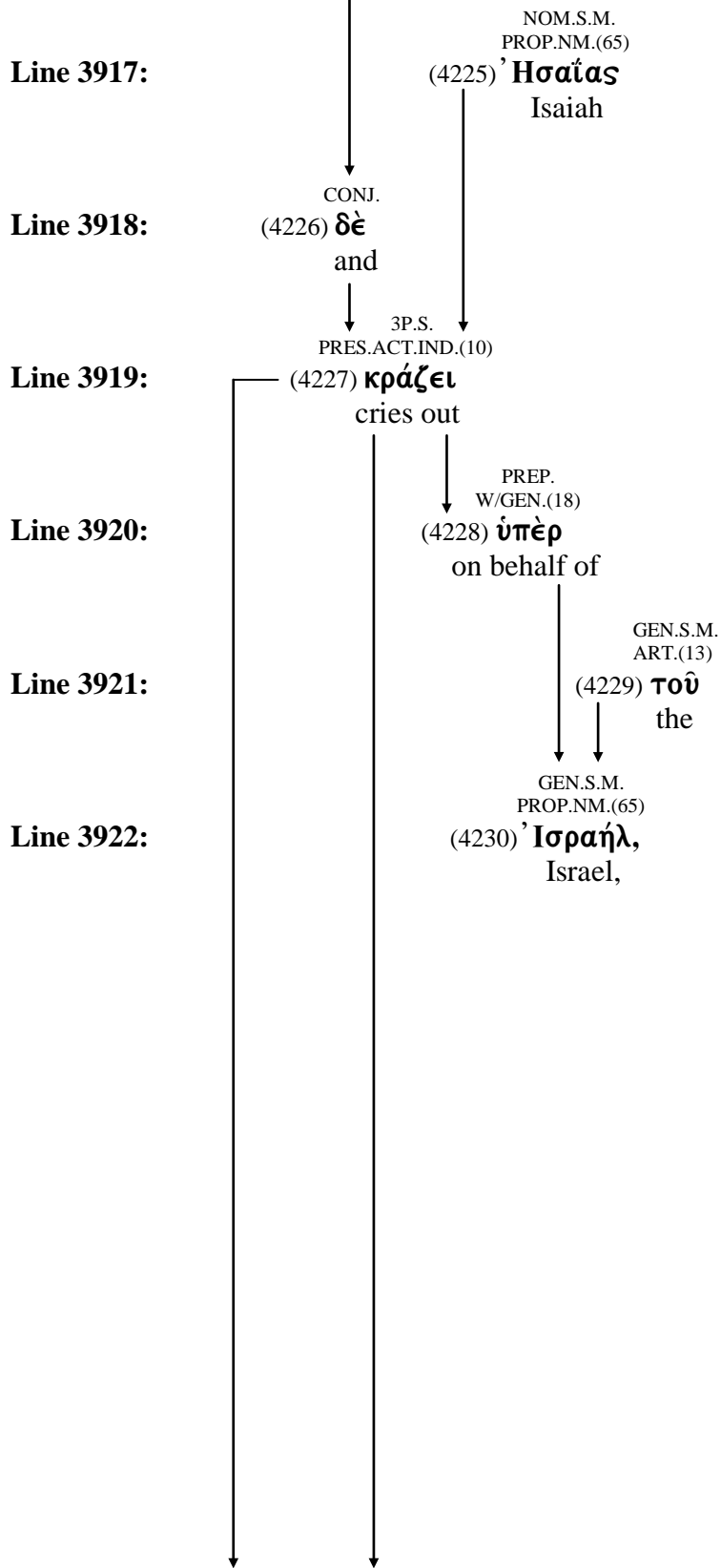

(4225) **Ἡσαΐας** - proper name = Isaiah

(4226) **δὲ** - conjunction = and, now, even

(4227) **κράζω** = to cry aloud

(4228) **ὑπέρ** - prep used with the genitive = on behalf of, for the sake of

(4229) **ὁ** - article = the

(4230) **Ἰσραήλ** denoting a descendant of Israel or Jacob
from **לְיִשְׂרָאֵל** = Israel, God rules, or ruled by God
from **רָצַח** = to prevail, to have power
and **אֱלֹהִים** = God, might, strength

Romans 9:27 Ἡσαΐας δὲ κρᾶζει ὑπὲρ τοῦ Ἰσραὴλ,
 Ἐὰν ᾗ ὁ ἀριθμὸς τῶν υἱῶν Ἰσραὴλ ὡς ἡ ἄμμος τῆς
 θαλάσσης, τὸ κατὰλειμμα (ὑπόλειμμα) σωθήσεται·

Romans 9:27 Diagram

Line 3923:

CONJ.
 (4231) Ἐὰν
 If

Line 3924:

3P.S.
 PRES.ACT.SUBJ.(26)
 (4232) ᾗ
 should be

Line 3925:

NOM.S.M.
 ART.(13)
 (4233) ὁ
 the

Line 3926:

NOM.S.M.
 2DEC.N.(12)
 (4234) ἀριθμὸς
 number

Line 3927:

GEN.PL.M.
 ART.(13)
 (4235) τῶν
 the

Line 3928:

GEN.PL.M.
 2DEC.N.(12)
 (4236) υἱῶν
 of sons

Line 3929:

GEN.S.M.
 PROP.NM.(65)
 (4237) Ἰσραὴλ
 of Israel

(4231) **ἐάν** - particle = if
from **εἰ** - conjunction = if, whether
and **ἄν** - a particle of supposition or possibility

(4232) **εἰμί** = to be, exist

(4233) **ὁ** - article = the

(4234) **ἀριθμός** = number, sum, total
from **αἴρω** = to raise, to lift up

(4235) **ὁ** - article = the

(4236) **υἱός** = son, descendant

(4237) **Ἰσραήλ** denoting a descendant of Israel or Jacob
from **לְאֱלֹהֵי יִשְׂרָאֵל** = Israel, God rules, or ruled by God
from **יָצַח** = to prevail, to have power
and **אֱלֹהִים** = God, might, strength

Romans 9:27 Diagram

Romans 9:27 Ἡσαΐας δὲ κρᾶζει ὑπὲρ τοῦ Ἰσραὴλ,
 Ἐὰν ᾗ ὁ ἀριθμὸς τῶν υἱῶν Ἰσραὴλ ὡς ἡ ἄμμος τῆς
 θαλάσσης, τὸ κατάλειμμα (ὑπόλειμμα) σωθήσεται·

Line 3930:

PARTICLE
 (4238) ὡς
 as

Line 3931:

NOM.S.F.
 ART.(13)
 (4239) ἡ
 the

Line 3932:

NOM.S.F.
 2DEC.N.(12)
 (4240) ἄμμος
 sand

Line 3933:

GEN.S.F.
 ART.(13)
 (4241) τῆς
 the

Line 3934:

GEN.S.F.
 1DEC.N.(15)
 (4242) θαλάσσης,
 of sea,

Line 3935:

NOM.S.N.
 ART.(13)
 (4243) τὸ
 the

Line 3936:

NOM.S.N.
 3DEC.N.(40)
 (4244) κατάλειμμα
 remnant

NOM.S.N.
 3DEC.N.(40)
 ((4245) υπόλειμμα)
 (remnant)

Line 3937:

3P.S.
 FUT.PASS.IND.(38)
 (4246) σωθήσεται·
 will be saved;

- (4238) **ὡς** - adverb used as a comparative particle = as, like
from **ὅς** - relative pronoun = who, which, what
- (4239) **ὁ** - article = the
- (4240) **ἄμμος** = something heaped up on shore, sand
from **ἄμα** - particle = with, together
- (4241) **ὁ** - article = the
- (4242) **θάλασσα** = sea, lake
from **ἅλς** = salt, saltiness
- (4243) **ὁ** - article = the
- (4244) **κατάλειμμα** = residue, remnant
from **καταλείπω** = to leave behind
from **κατά** - preposition = against, down, according to
and **λείπω** = to leave, be absent, to lack
- (4245) **ὑπόλειμμα** = a remnant
from **ὑπολείπω** = to leave behind
from **ὑπό** - preposition = under
and **λείπω** = to leave, be absent, to lack
- (4246) **σώζω** = to save, deliver, rescue

Romans 9:28 Diagram

Romans 9:28 λόγον γὰρ συντελῶν καὶ συντέμνων
 [ἐν δικαιοσύνη· ὅτι λόγον συντετμημένον] ποιήσει
 Κύριος ἐπὶ τῆς γῆς.

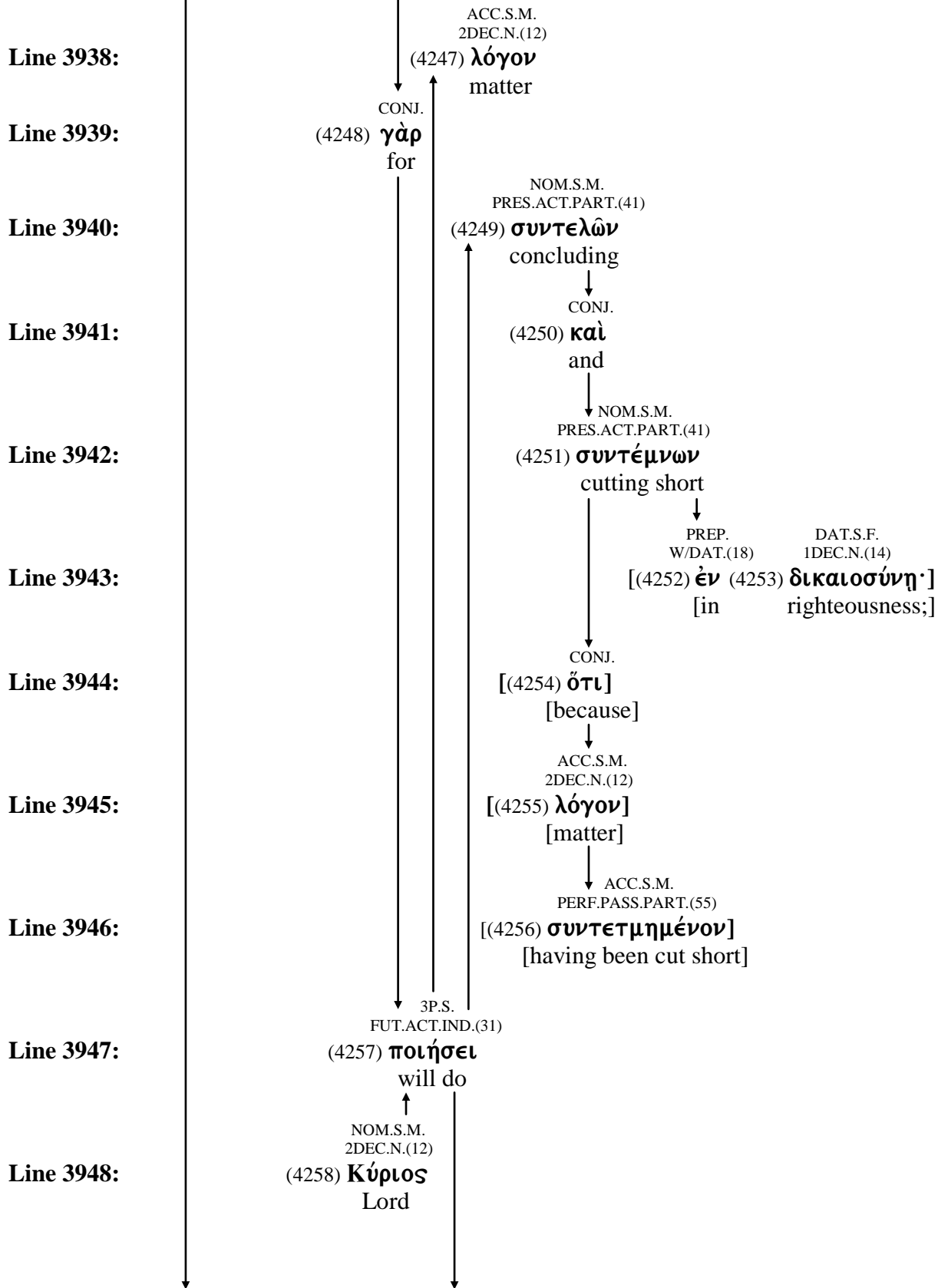

- (4247) **λόγος** = word
from **λέγω** = to speak, to say
- (4248) **γάρ** - conjunction = for
- (4249) **συντελέω** = to complete, to fulfill, to bring to an end
from **σύν** - preposition = with
and **τελέω** = to finish, to end, to complete
from **τέλος** = end, final, goal
from **τέλλω** = to reach for a goal
- (4250) **καί** - conjunction = and, also, even
- (4251) **συντέμνω** = to shorten, to cut short
from **σύν** - preposition = with
and **τομός** - adjective = sharp
from **τέμνω** = to cut
- (4252) **έν** - preposition used with the dative = in
- (4253) **δικαιοσύνη** = righteousness
from **δίκαιος** = righteous, just, right
from **δίκη** = judgment, execution of a sentence, punishment
- (4254) **ὅτι** - conjunction = that, because
- (4255) **λόγος** = word
from **λέγω** = to speak, to say
- (4256) **συντέμνω** = to shorten, to cut short
from **σύν** - preposition = with
and **τομός** - adjective = sharp
from **τέμνω** = to cut
- (4257) **ποιέω** = to make, to do
- (4258) **κύριος** = lord, master
from **κύρος** = supremacy

Romans 9:28 Diagram

Romans 9:28 λόγον γὰρ συντελῶν καὶ συντέμνων
[ἐν δικαιοσύνῃ· ὅτι λόγον συντετμημένον] ποιήσει
Κύριος ἐπὶ τῆς γῆς.

Line 3949:

PREP.
W/GEN.(18)
(4259) ἐπὶ
upon

Line 3950:

GEN.S.F.
ART.(13)
(4260) τῆς
the

Line 3951:

GEN.S.F.
IDEC.N.(14)
(4261) γῆς.
earth.

Romans 9:28 Word Study

(4259) ἐπί - preposition used with the genitive = over, upon

(4260) ὁ - article = the

(4261) γῆ = the earth, land

Romans 9:29 καὶ καθὼς προείρηκεν Ἰσαΐας, Εἰ μὴ Κύριος Σαβαὼθ ἐγκατέλιπεν ἡμῖν σπέρμα, ὡς Σόδομα ἂν ἐγενήθημεν, καὶ ὡς Γόμορρα ἂν ὠμοιώθημεν.

Romans 9:29 Diagram

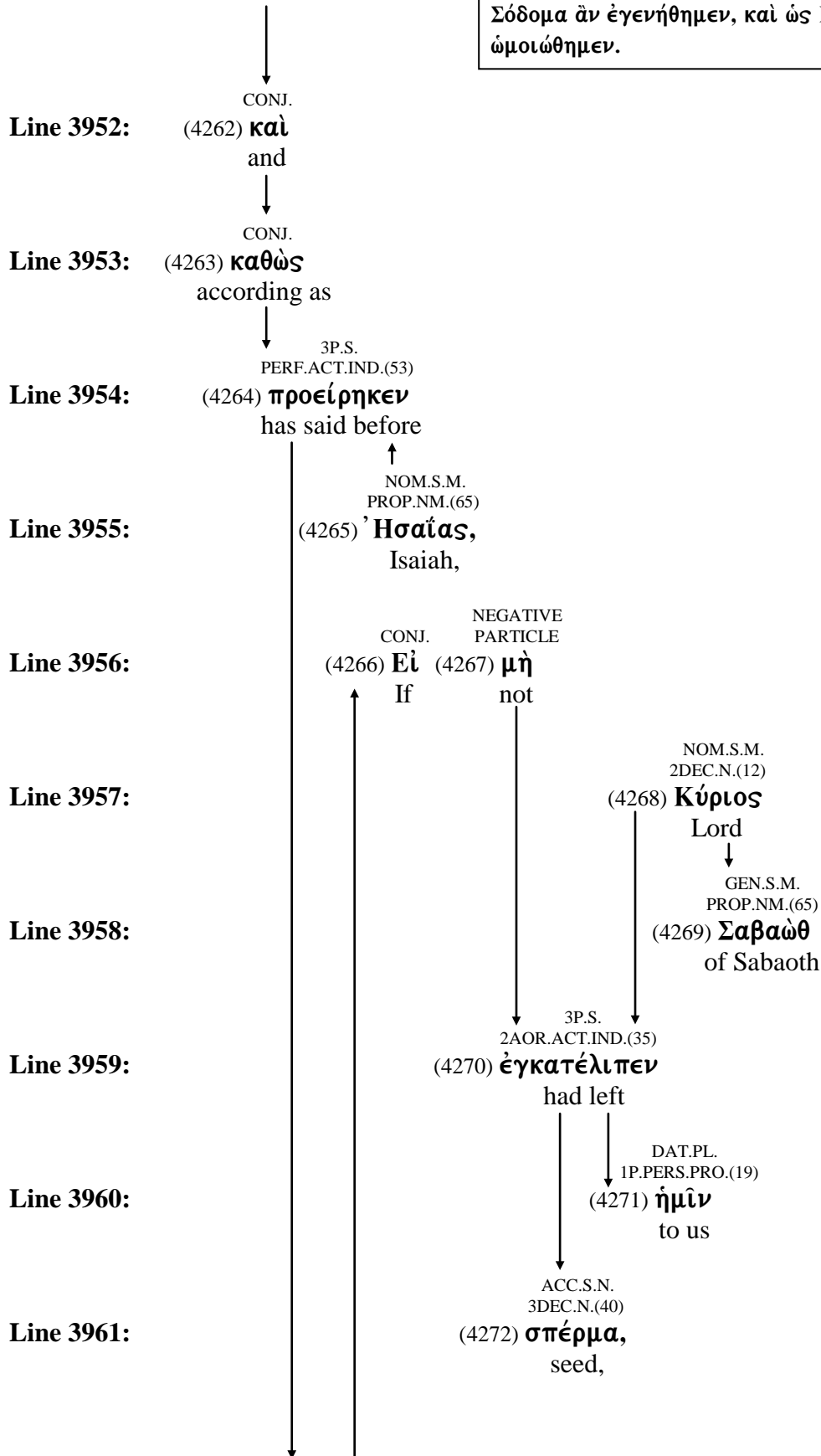

- (4262) **καί** - conjunction = and, also, even
- (4263) **καθὼς** - conjunction = according as, just as
from **κατά** - preposition = according to
and **ὡς** - adverb = as, like
- (4264) **προεἶπον** = to speak before, to say in advance
from **πρό** - preposition = with
and **εἶπον** = to speak, say, command
- (4265) **Ἰσαΐας** - proper name = Isaiah
- (4266) **εἰ** - conjunction = if
- (4267) **μή** - negative particle = no, not
- (4268) **κύριος** = lord, master
from **κύρος** = supremacy
- (4269) **Σαβαώθ** - proper name = armies, hosts
- (4270) **ἐγκαταλείπω** = to desert, to abandon, to leave
from **ἐν** - preposition = in
and **καταλείπω** = to forsake, to leave behind
from **κατά** - preposition = down, back, apart
and **λείπω** = to leave, be lacking
- (4271) **ἐγώ** - first person personal pronoun = I
- (4272) **σπέρμα** = seed
from **σπείρω** = to sow, scatter, seed

Romans 9:29 Diagram

Romans 9:29 καὶ καθὼς προείρηκεν Ἡσαΐας, Εἰ μὴ
 Κύριος Σαβαὼθ ἐγκατέλιπεν ἡμῖν σπέρμα, ὡς
 Σόδομα ἂν ἐγενήθημεν, καὶ ὡς Γόμορρα ἂν
 ὁμοιωθῆμεν.

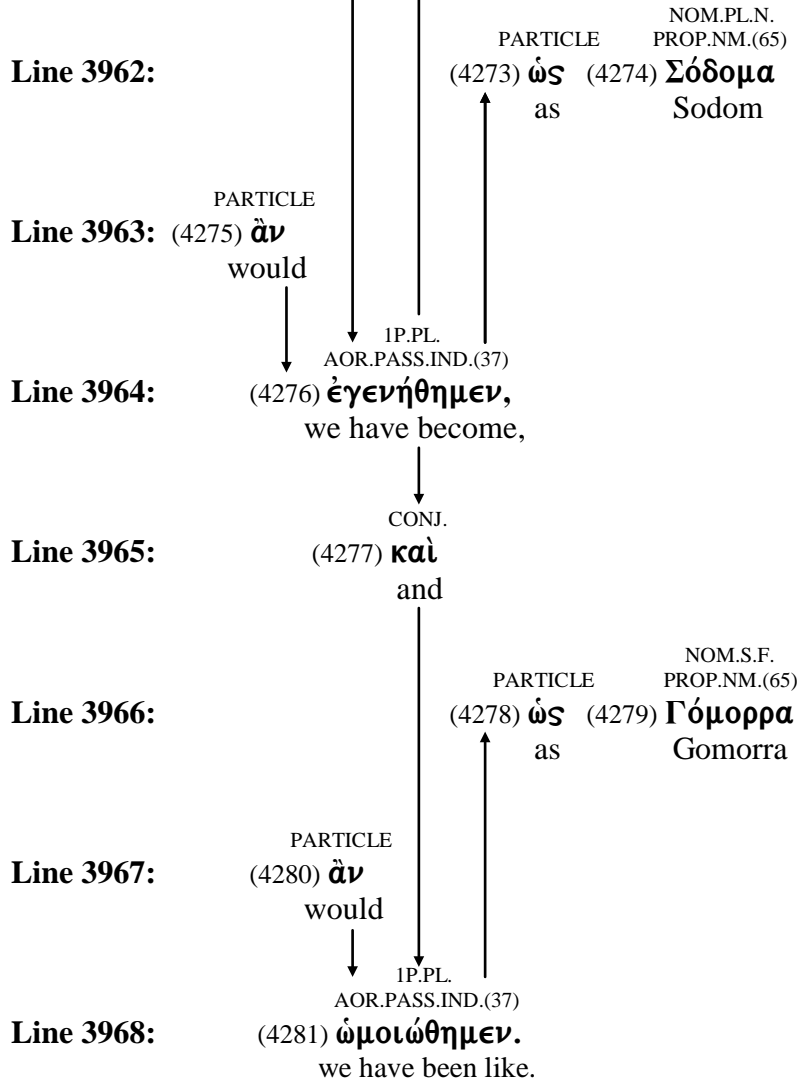

(4273) **ὡς** - adverb used as a comparative particle = as, like
from **ὅς** - relative pronoun = who, which, what

(4274) **Σόδομα** - proper name = Sodom

(4275) **ἄν** - particle = denoting supposition or possibility

(4276) **γίνομαι** = to become

(4277) **καί** - conjunction = and, also, even

(4278) **ὡς** - adverb used as a comparative particle = as, like
from **ὅς** - relative pronoun = who, which, what

(4279) **Γόμορρα** - name = Gomorroah

(4280) **ἄν** - particle = denoting supposition or possibility

(4281) **ὁμοιόω** = to be like, to make like
from **ὅμοιος** - adjective = like, liken
from **ὁμοῦ** - adverb = same, together

