

Lesson Twenty-Five

Romans 7:1-6

- 1) Ἦ ἀγνοεῖτε, ἀδελφοί, γινώσκουσι(ν) γὰρ νόμον λαλῶ,
Or are you ignorant, brothers, knowing for law I am speaking,
ὅτι ὁ νόμος κυριεύει τοῦ ἀνθρώπου ἐφ' ὅσον χρόνον
that the law is ruling over the man over as long as time
ζῆ;
he should live?
- 2) ἡ γὰρ ὑπανδρος γυνή τῷ ζῶντι ἀνδρὶ δέδεται νόμῳ·
the for under-husband woman the to living husband has been bound law;
ἐὰν δὲ ἀποθάνῃ ὁ ἀνὴρ, κατήρηται ἀπὸ τοῦ νόμου τοῦ
if and should die the husband, she is released from the law the
ἀνδρός.
of husband.
- 3) ἄρα οὖν ζῶντος τοῦ ἀνδρός μοιχαλὶς χρηματίσει, ἐὰν
then therefore while living the husband adulteress she will be called, if
γένηται ἀνδρὶ ἑτέρῳ· ἐὰν δὲ ἀποθάνῃ ὁ ἀνὴρ, ἐλευθέρα
she should become to man another; if but should die the husband, free
ἐστὶν ἀπὸ τοῦ νόμου, τοῦ μὴ εἶναι αὐτὴν μοιχαλίδα,
she is from the law, the not to be her adulteress,
γενομένην ἀνδρὶ ἑτέρῳ.
having become to man another.
- 4) ὥστε, ἀδελφοί μου, καὶ ὑμεῖς ἐθανατώθητε τῷ νόμῳ διὰ
so that, brothers of me, also yourselves you became dead the to law through
τοῦ σώματος τοῦ Χριστοῦ, εἰς τὸ γενέσθαι ὑμᾶς ἑτέρῳ,
the body the of Christ, for the to become you to another,
τῷ ἐκ νεκρῶν ἐγερέντι, ἵνα καρποφορήσωμεν τῷ
to the One out of dead having been raised, in order that we might bear fruit the
Θεῷ.
to God.

- 5) ὅτε γὰρ ἡμεν ἐν τῇ σαρκί, τὰ παθήματα τῶν ἁμαρτιῶν τὰ
when for we were in the flesh, the passions the of sins the ones
διὰ τοῦ νόμου ἐνηργεῖτο ἐν τοῖς μέλεσιν ἡμῶν εἰς τὸ
through the law were working in the members of us for the
καρποφορῆσαι τῷ θανάτῳ·
to bear fruit the to death;
- 6) νυνὶ δὲ κατηργήθημεν ἀπὸ τοῦ νόμου, ἀποθανόντες ἐν ᾧ
now but we became released from the law, having died in which
κατειχόμεθα, ὥστε δουλεύειν ἡμᾶς ἐν καινότητι πνεύματος,
we were being held, so that to serve us in newness of spirit,
καὶ οὐ παλαιότητι γράμματος.
and not oldness of letter.

Word Association Diagram

Romans 7:1-6

Verse 1

Line 2443:

(2658) Ἡ

Line 2444:

(2659) ἀγνοεῖτε,

Line 2445:

(2660) ἀδελφοί,

Line 2446:

(2661) γινώσκουσι(ν)

Line 2447:

(2662) γὰρ

Line 2448:

(2663) νόμον

Line 2449:

(2664) λαλῶ,

Line 2450:

(2665) ὅτι

Line 2451:

(2666) ὁ

Line 2452:

(2667) νόμος

Line 2453:

(2668) κυριεύει

Line 2454:

(2669) τοῦ

Line 2455:

(2670) ἀνθρώπου

Line 2456:

(2671) ἐφ’

Line 2457:

(2672) ὅσον

Line 2458:

(2673) χρόνον

Line 2459:

(2674) ζῆ;

Verse 2

Line 2460:

(2675) ἡ

Line 2461:

(2676) γὰρ

Line 2462:

(2677) ὑπανδρος

Line 2463:

(2678) γυνῆ

Line 2464:

(2679) τῷ

Line 2465:

(2680) ζῶντι

Line 2466:

(2681) ἀνδρὶ

Line 2467:

(2682) δέδεται

Line 2468:

(2683) νόμῳ

Word Association Diagram

Romans 7:1-6

Verse 2 continued

Line 2469:

Line 2470:

Line 2471:

Line 2472:

Line 2473:

Line 2474:

Line 2475:

Line 2476:

Line 2477:

Line 2478:

Line 2479:

Verse 3

Line 2480:

Line 2481:

Line 2482:

Line 2483:

Line 2484:

Line 2485:

Line 2486:

Line 2487:

Line 2488:

Line 2489:

Line 2490:

Line 2491:

Line 2492:

Line 2493:

Line 2494:

Line 2495:

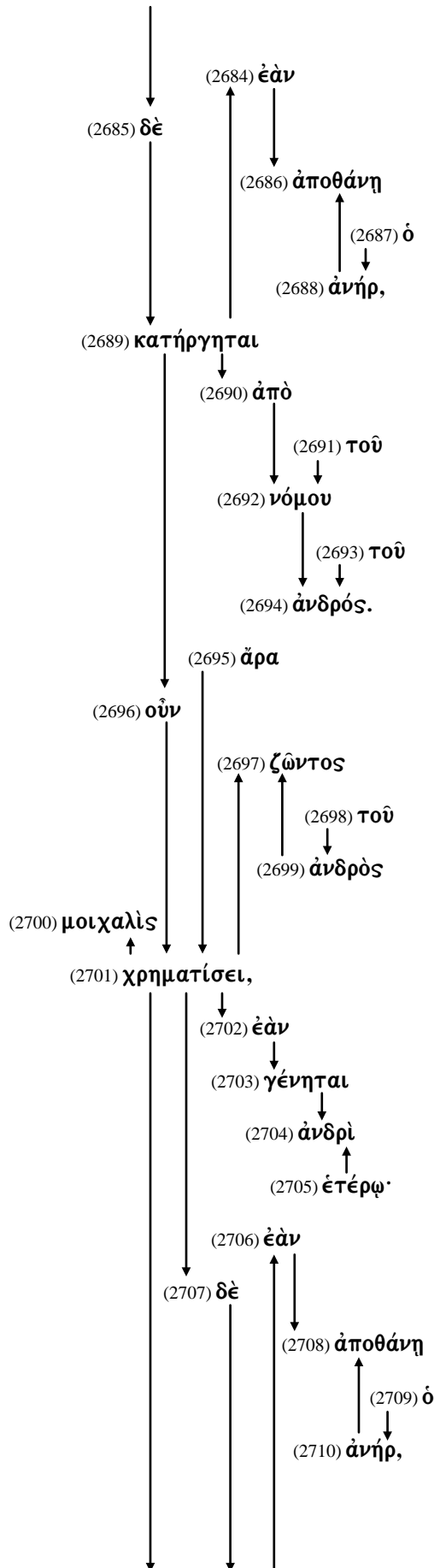

Word Association Diagram

Romans 7:1-6

Verse 3 continued

Line 2496:

Line 2497:

Line 2498:

Line 2499:

Line 2500:

Line 2501:

Line 2502:

Line 2503:

Line 2504:

Line 2505:

Line 2506:

Line 2507:

Line 2508:

Verse 4

Line 2509:

Line 2510:

Line 2511:

Line 2512:

Line 2513:

Line 2514:

Line 2515:

Line 2516:

Line 2517:

Line 2518:

Line 2519:

Line 2520:

Line 2521:

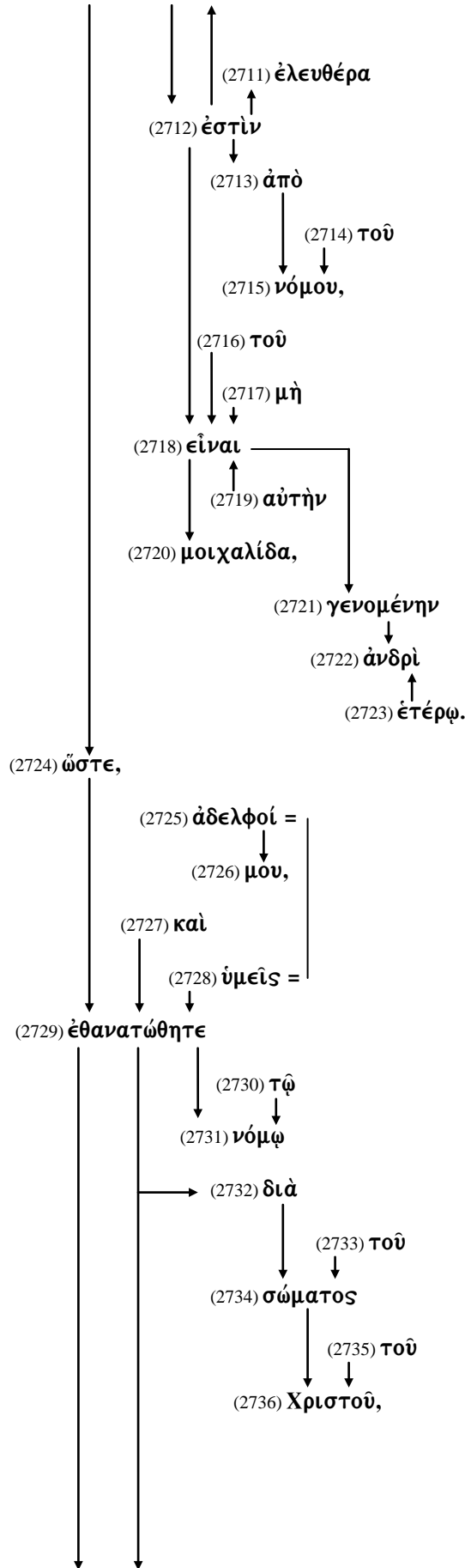

Word Association Diagram

Romans 7:1-6

Verse 4 continued

Line 2522:

Line 2523:

Line 2524:

Line 2525:

Line 2526:

Line 2527:

Line 2528:

Line 2529:

Line 2530:

Line 2531:

Line 2532:

Line 2533:

Verse 5

Line 2534:

Line 2535:

Line 2536:

Line 2537:

Line 2538:

Line 2539:

Line 2540:

Line 2541:

Line 2542:

Line 2543:

Line 2544:

Line 2545:

Line 2546:

Line 2547:

Line 2548:

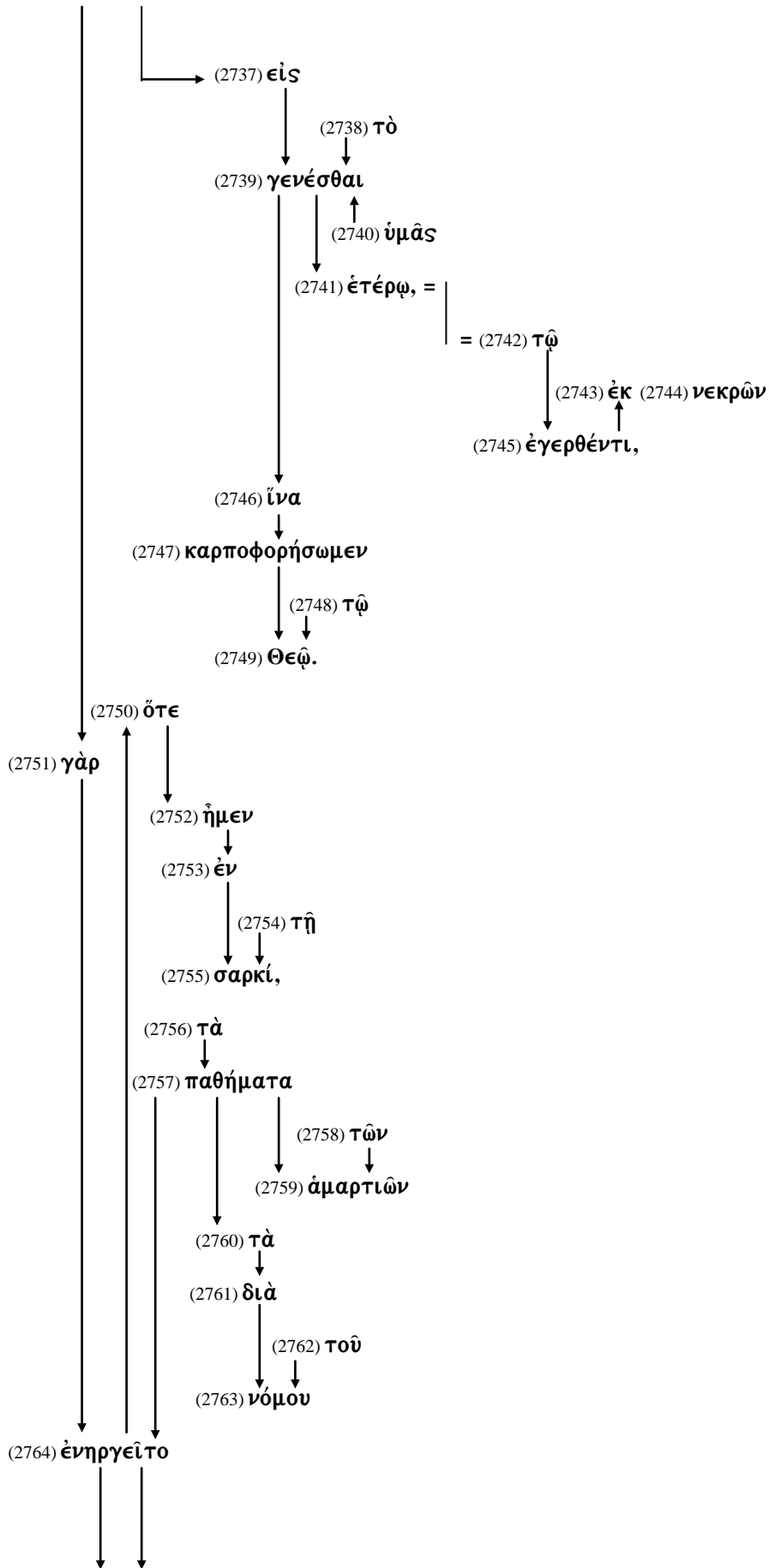

Word Association Diagram

Romans 7:1-6

Verse 5 continued

Line 2549:

Line 2550:

Line 2551:

Line 2552:

Line 2553:

Line 2554:

Line 2555:

Line 2556:

Line 2557:

Verse 6

Line 2558:

Line 2559:

Line 2560:

Line 2561:

Line 2562:

Line 2563:

Line 2564:

Line 2565:

Line 2566:

Line 2567:

Line 2568:

Line 2569:

Line 2570:

Line 2571:

Line 2572:

Line 2573:

Line 2574:

Line 2575:

Line 2576:

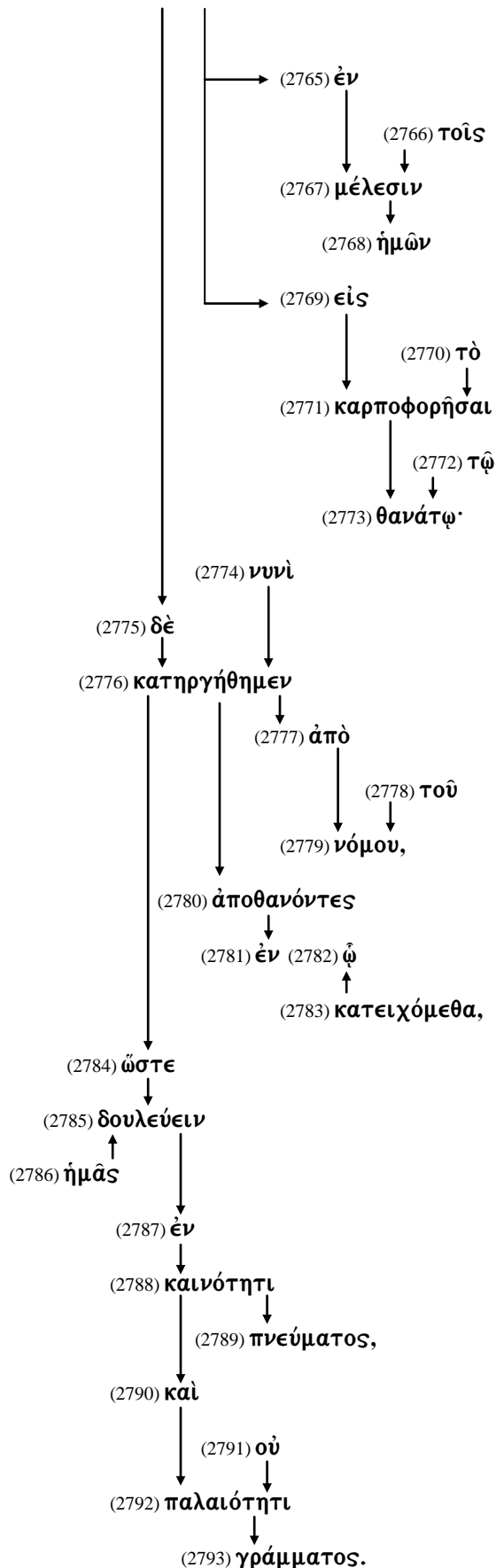

I Romans 1:1-17
The Introduction

II Romans 1:18-11:36
The Doctrine of the Christian Faith

Romans 1:18-3:20
The Indictment: The Doctrine of Condemnation

Romans 3:21-5:21
The Imputation: The Doctrine of Justification

Romans 6:1-8:39
The Impartation: The Doctrine of Sanctification

Romans chapters 6-7 are systematically arranged around four questions:

- 1) **Romans 6:1**
- 2) **Romans 6:15**
- 3) **Romans 7:7**
- 4) **Romans 7:13**

Romans 6 The Power over Sin
Romans 6:1-14 The Principles of Sanctification
Romans 6:15-23 The Process of Sanctification

Romans 7 The Problem of the Flesh
Romans 7:1-6 The Precepts of Sanctification
Romans 7:7-13 The Perception of Sanctification
Romans 7:14-25 The Performance of Sanctification

Romans 8 The Provision of the Spirit
Romans 8:1-4 The Plan of Sanctification
Romans 8:5-11 The Procedure of Sanctification
Romans 8:12-17 The Product of Sanctification
Romans 8:18-25 The Patience in Sanctification
Romans 8:26-30 The Provision of Sanctification
Romans 8:31-39 The Position in Sanctification

Lesson Twenty-Five

Romans 7:1-6

Diagrams

Romans 7:1 Diagram

Romans 7:1 Ἡ ἀγνοεῖτε, ἀδελφοί, γινώσκουσι(ν) γὰρ νόμον λαλῶ, ὅτι ὁ νόμος κυριεύει τοῦ ἀνθρώπου ἐφ' ὅσον χρόνον ζῆ;

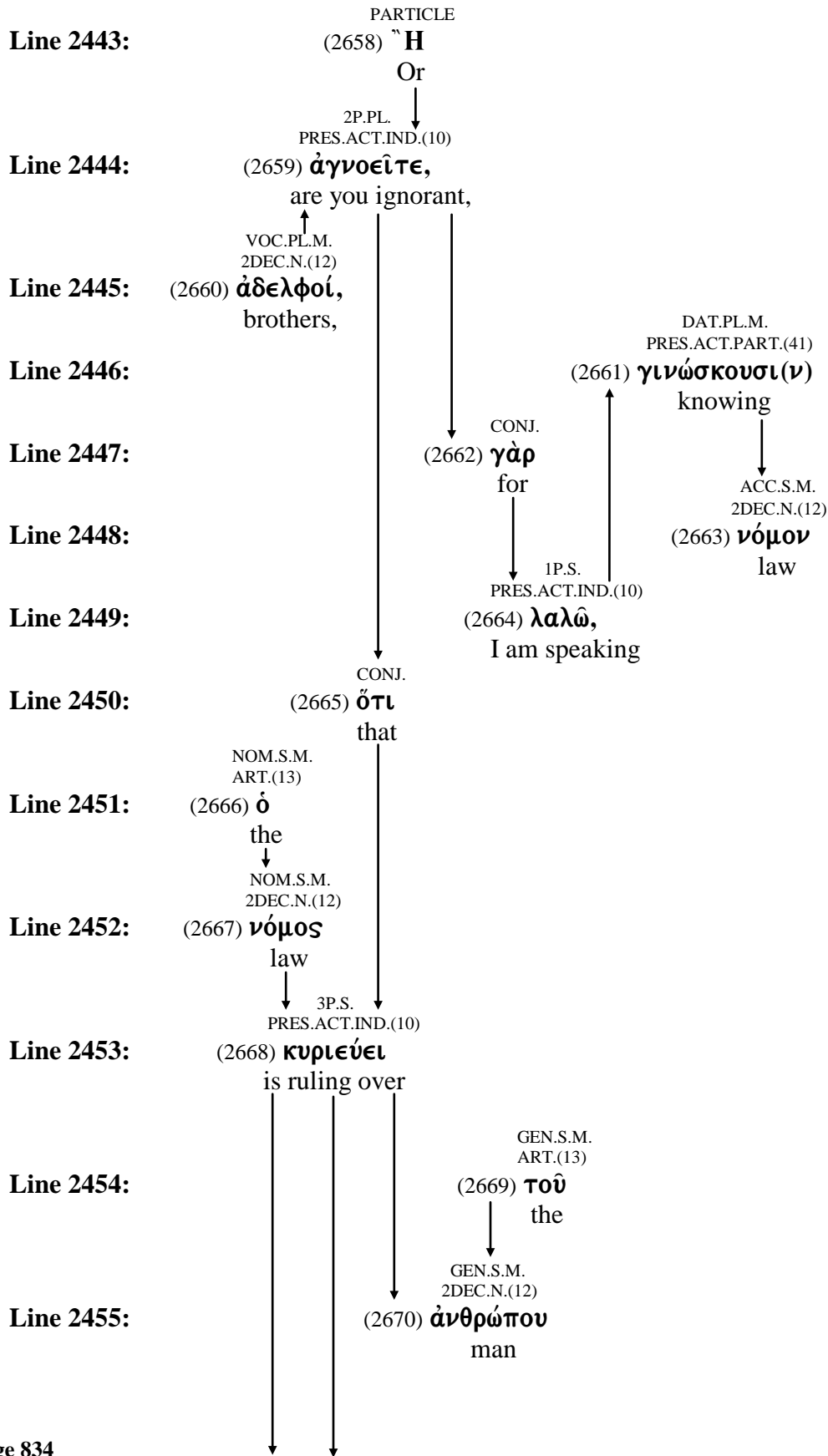

(2658) ἢ - particle used as a conjunction = or

(2659) ἀγνοέω = to be ignorant, without understanding, without knowledge
from α - used as a negative particle = without
and νοέω = perception, understanding

(2660) ἀδελφός = brother
from ἀ - connecting particle
and δελφύς = the womb

(2661) γινώσκω = to know

(2662) γάρ - conjunction = for

(2663) νόμος = a law, a command, anything established

(2664) λαλέω = to make vocal utterance, to babble, to talk

(2665) ὅτι - conjunction = that, because

(2666) ὁ - article = the

(2667) νόμος = a law, a command, anything established

(2668) κύριος = lord, master
from κύρος = supremacy

(2669) ὁ - article = the

(2670) ἄνθρωπος = a man, a human being
from ἀνήρ = a male
and ὄψ = the face or countenance

Romans 7:1 Diagram

Romans 7:1 Ἡ ἀγνοεῖτε, ἀδελφοί, γινώσκουσι(ν) γὰρ νόμον λαλῶ, ὅτι ὁ νόμος κυριεύει τοῦ ἀνθρώπου ἐφ' ὅσον χρόνον ζῆ;

Line 2456:

PREP.
W/ACC.(12)
(2671) ἐφ'
over

Line 2457:

ACC.S.M.
REL.PRO.(62)
(2672) ὅσον
as long as

Line 2458:

ACC.S.M.
2DEC.N.(12)
(2673) χρόνον
time

Line 2459:

3P.S.
PRES.ACT.IND.(10)
(2674) ζῆ;
he should live?

(2671) **ἐπί** - preposition used with the accusative = on, to, against

(2672) **ὅσος** - relative pronoun = as many as, as great as
from **ὅς** - relative pronoun = who, which, what

(2673) **χρόνος** = time, chronological time

(2674) **ζάω** = to live, to breathe

Romans 7:2 Diagram

Romans 7:2 ἡ γὰρ ὑπανδρος γυνὴ τῷ ζῶντι ἀνδρὶ δέδεται νόμῳ· ἐὰν δὲ ἀποθάνῃ ὁ ἀνὴρ, κατήργηται ἀπὸ τοῦ νόμου τοῦ ἀνδρός.

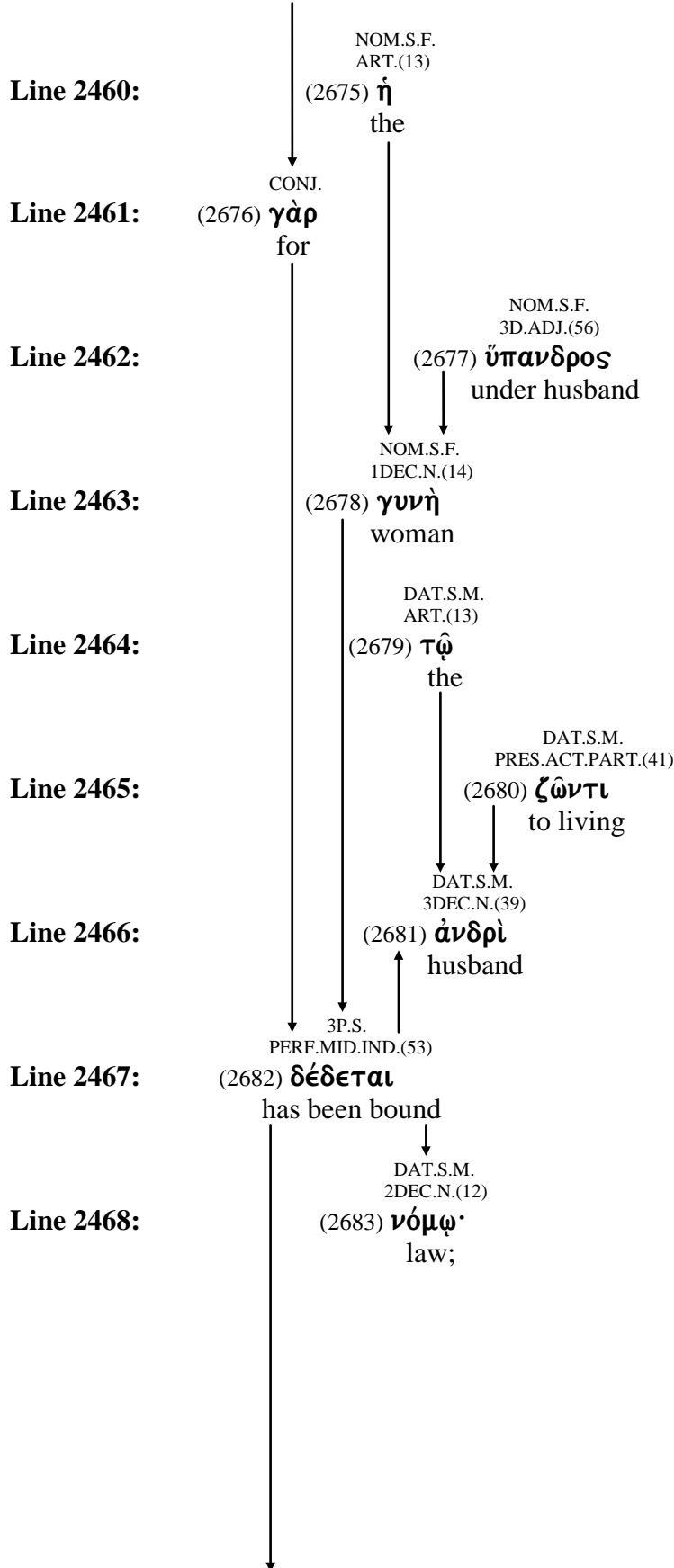

(2675) **ὁ** - article = the

(2676) **γάρ** - conjunction = for

(2677) **ὑπανδρος** = under-husband
from **ὑπό** - prep = under
and **άνήρ** = man, husband

(2678) **γυνή** = woman, wife

(2679) **ὁ** - article = the

(2680) **ζάω** = to live, to breathe

(2681) **άνήρ** = man, husband
from **άνθρωπος** = man, a human being

(2682) **δέω** = to tie, to bind

(2683) **νόμος** = a law, a command, anything established

Romans 7:2 ἡ γὰρ ὑπανδρος γυνὴ τῷ ζῶντι ἀνδρὶ δέδεται νόμῳ· ἐὰν δὲ ἀποθάνῃ ὁ ἀνὴρ, κατήρηται ἀπὸ τοῦ νόμου τοῦ ἀνδρός.

Romans 7:2 Diagram

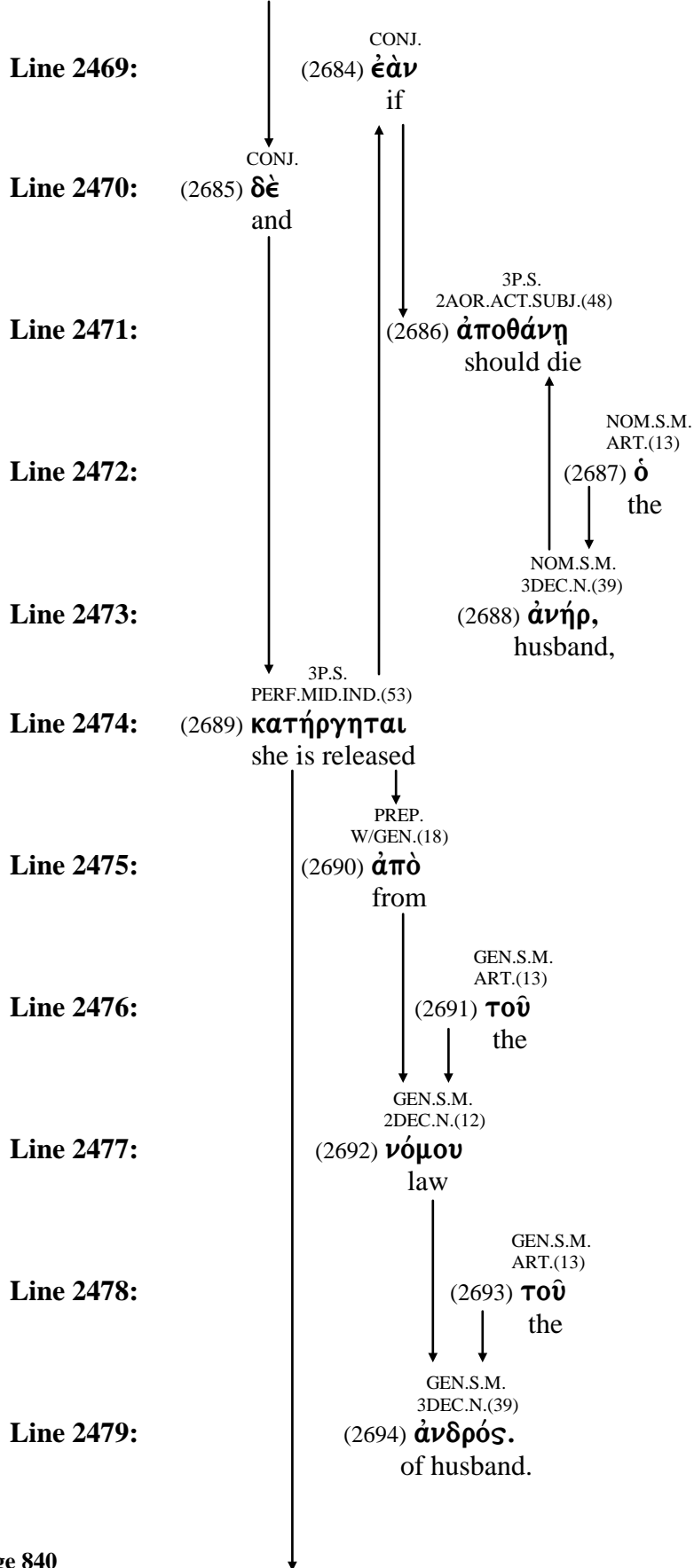

- (2684) **ἐάν** - particle used as a conditional conjunction = if
from **εἰ** - particle used as a conditional conjunction = if
and **ἄν** - particle used to express supposition or uncertainty
- (2685) **δὲ** - conjunction = and, now, even
- (2686) **ἀποθνήσκω** = to die
from **ἀπό** - preposition = from
and **θνήσκω** = to be dead
- (2687) **ὁ** - article = the
- (2688) **άνήρ** = man, husband
from **άνθρωπος** = man, a human being
- (2689) **καταργέω** = to make inactive or inoperative
from **κατά** - preposition = against, down
and **ἀργέω** = to be idle, inactive
from **ἀργός** - adjective = idle, without work
from **α** as a negative particle
and **ἔργον** = to work
- (2690) **ἀπό** - preposition used with the genitive = from, out of
- (2691) **ὁ** - article = the
- (2692) **νόμος** = a law, a command, anything established
- (2693) **ὁ** - article = the
- (2694) **άνήρ** = man, husband
from **άνθρωπος** = man, a human being

Romans 7:3 Diagram

Romans 7:3 ἄρα οὖν ζῶντος τοῦ ἀνδρὸς μοιχαλῖς χρηματίσει, ἐὰν γένηται ἀνδρὶ ἑτέρῳ· ἐὰν δὲ ἀποθάνῃ ὁ ἀνὴρ, ἐλευθέρα ἐστὶν ἀπὸ τοῦ νόμου, τοῦ μὴ εἶναι αὐτὴν μοιχαλίδα, γενομένην ἀνδρὶ ἑτέρῳ.

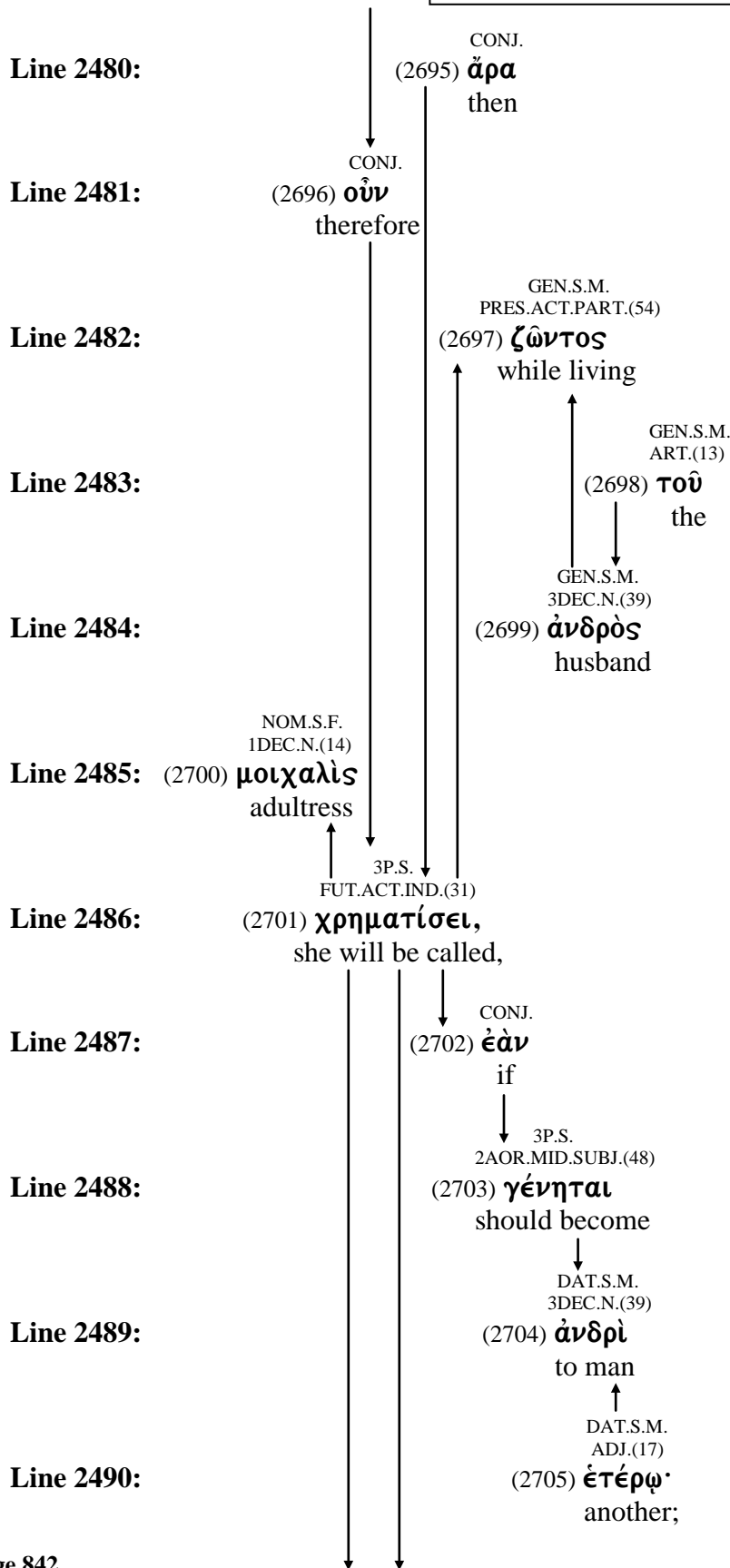

- (2695) **ἄρα** - particle = since, then
from **αἴρω** = to raise, to lift
- (2696) **οὖν** - particle = therefore, then
- (2697) **ζάω** = to live, to breathe
- (2698) **ὁ** - article = the
- (2699) **άνήρ** = man, husband
from **άνθρωπος** = man, a human being
- (2700) **μοιχαλίσ** - adjective = adultress, adulterous
from **μοιχός** = adulterer
- (2701) **χρηματίζω** = to have revelation, to name
from **χρήμα** = something useful
- (2702) **ἐάν** - particle used as a conditional conjunction = if
from **εἰ** - particle used as a conditional conjunction = if
and **ἄν** - particle used to express supposition or uncertainty
- (2703) **γίνομαι** = to become
- (2704) **άνήρ** = man, husband
from **άνθρωπος** = man, a human being
- (2705) **ἕτερος** - adjective = the other, another

Romans 7:3 Diagram

Romans 7:3 ἄρα οὖν ζῶντος τοῦ ἀνδρὸς μοιχαλῖς
 χρηματίσει, ἐὰν γένηται ἀνδρὶ ἑτέρῳ· ἐὰν δὲ ἀποθάνῃ ὁ
 ἀνὴρ, ἐλευθέρα ἐστὶν ἀπὸ τοῦ νόμου, τοῦ μὴ εἶναι αὐτὴν
 μοιχαλίδα, γενομένην ἀνδρὶ ἑτέρῳ.

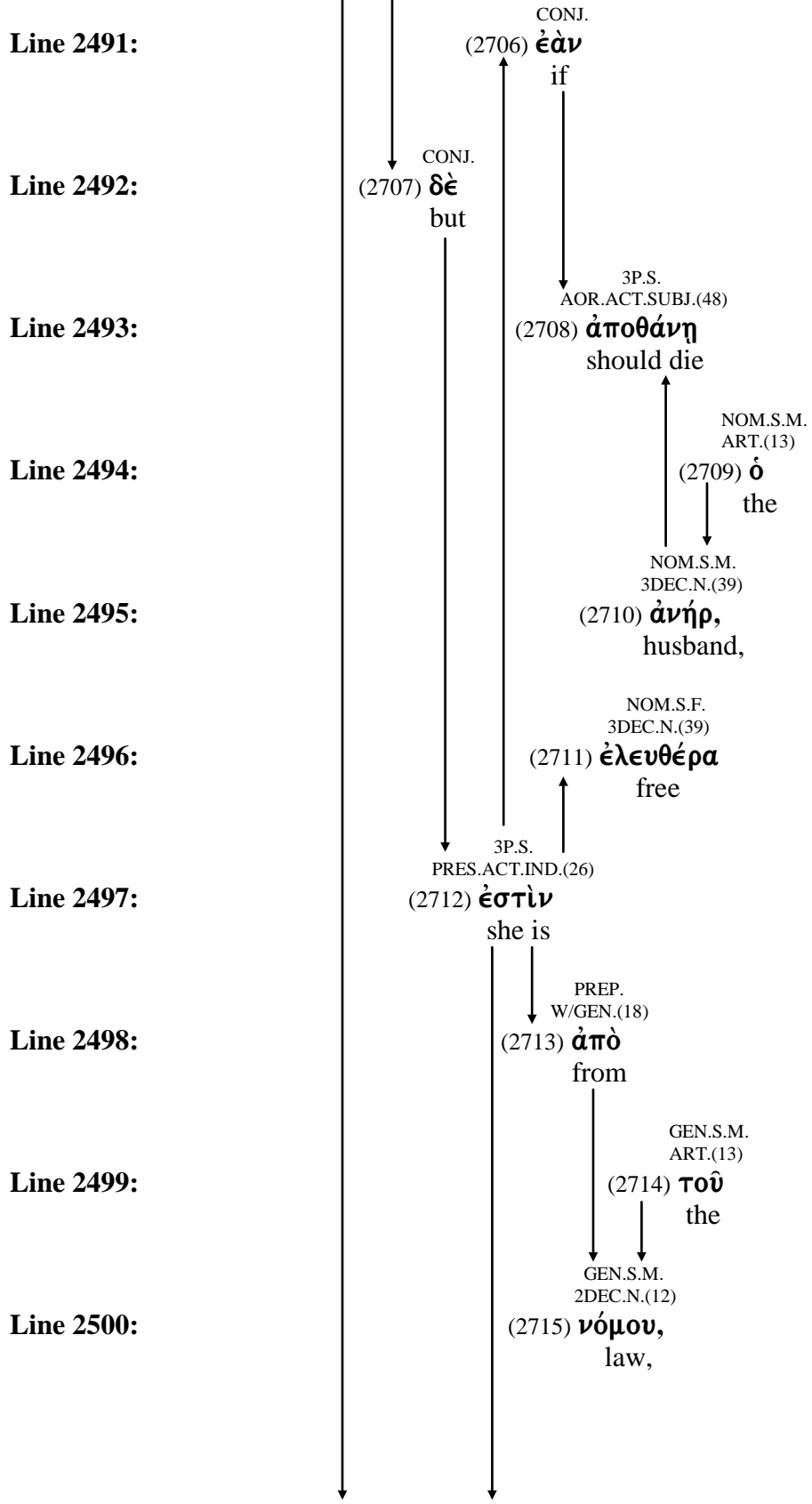

- (2706) **ἐάν** - particle used as a conditional conjunction = if
from **εἰ** - particle used as a conditional conjunction = if
and **ἄν** - particle used to express supposition or uncertainty
- (2707) **δέ** - conjunction = and, now, even
- (2708) **ἀποθνήσκω** = to die
from **ἀπό** - preposition = from
and **θνήσκω** = to be dead
- (2709) **ὁ** - article = the
- (2710) **άνήρ** = man, husband
from **άνθρωπος** = man, a human being
- (2711) **ἐλεύθερος** - adjective = free, freedom
from **έρχομαι** = to come, to go
- (2712) **εἰμί** = to be, exist
- (2713) **ἀπό** - preposition used with the genitive = from, out of
- (2714) **ὁ** - article = the
- (2715) **νόμος** = a law, a command, anything established

Romans 7:3 Diagram

Romans 7:3 ἄρα οὖν ζῶντος τοῦ ἀνδρὸς μοιχαλῖς χρηματίσει, ἐὰν γένηται ἀνδρὶ ἑτέρῳ· ἐὰν δὲ ἀποθάνῃ ὁ ἀνὴρ, ἐλευθέρα ἐστὶν ἀπὸ τοῦ νόμου, τοῦ μὴ εἶναι αὐτὴν μοιχαλίδα, γενομένην ἀνδρὶ ἑτέρῳ.

Line 2501:

GEN.S.M.
ART.(13)
(2716) τοῦ
the

Line 2502:

NEG.
PART.
(2717) μὴ
not

Line 2503:

PRES.ACT.INF.(50)
(2718) εἶναι
to be

Line 2504:

ACC.S.F.
3P.PERS.PRO.(20)
(2719) αὐτήν
her

Line 2505:

ACC.S.F.
3DEC.N.(39)
(2720) μοιχαλίδα,
adultrous,

Line 2506:

ACC.S.F.
2AOR.MID.PART.(44)
(2721) γενομένην
having become

Line 2507:

DAT.S.F.
3DEC.N.(39)
(2722) ἀνδρὶ
to man

Line 2508:

DAT.S.M.
ADJ.(17)
(2723) ἑτέρῳ.
another.

(2716) **ὁ** - article = the

(2717) **μή** - negative particle = no, not

(2718) **εἰμί** = to be, exist

(2719) **αὐτός** - third person personal pronoun = he, she, it

(2720) **μοιχαλῖς** - adjective = adultress, adulterous
from **μοιχός** = adulterer

(2721) **γίνομαι** = to become

(2722) **άνήρ** = man, husband
from **άνθρωπος** = man, a human being

(2723) **ἕτερος** - adjective = the other, another

Romans 7:4 ὥστε, ἀδελφοί μου, καὶ ὑμεῖς ἐθανατώθητε τῷ νόμῳ διὰ τοῦ σώματος τοῦ Χριστοῦ, εἰς τὸ γενέσθαι ὑμᾶς ἐτέρῳ, τῷ ἐκ νεκρῶν ἐγερθέντι, ἵνα καρποφορήσωμεν τῷ Θεῷ.

Romans 7:4 Diagram

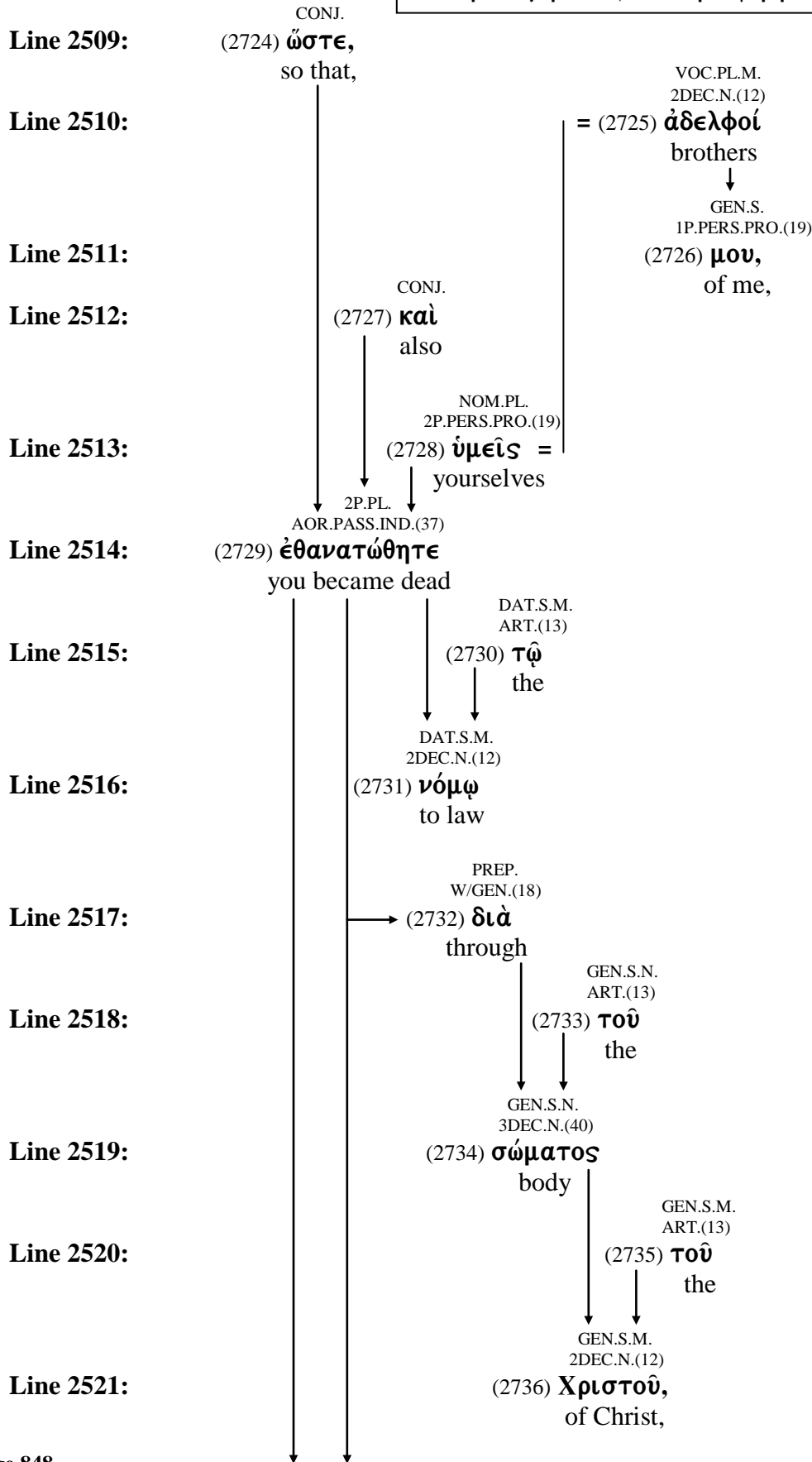

(2724) ὥστε - conjunction = so that, so then, insomuch that
from ὡς - adverb = as, like
and τέ - particle = and, even, also

(2725) ἀδελφός = brother
from ἀ - connecting particle
and δελφύς = the womb

(2726) ἐγώ - first person personal pronoun = I

(2727) καί - conjunction = and, also, even

(2728) σύ - second person personal pronoun = you

(2729) θανατώω = to put to death, to kill, to destroy
from θάνατος = death

(2730) ὁ - article = the

(2731) νόμος = a law, a command, anything established

(2732) διά - preposition used with the genitive = through

(2733) ὁ - article = the

(2734) σῶμα = body

(2735) ὁ - article = the

(2736) Χριστός = Christ
meaning “anointed” - from χρίω = to anoint

Romans 7:4 Diagram

Romans 7:4 ὥστε, ἀδελφοί μου, καὶ ὑμεῖς ἐθανατώθητε τῷ νόμῳ διὰ τοῦ σώματος τοῦ Χριστοῦ, εἰς τὸ γενέσθαι ὑμᾶς ἑτέρῳ, τῷ ἐκ νεκρῶν ἐγερθέντι, ἵνα καρποφορήσωμεν τῷ Θεῷ.

Line 2522:

PREP.
W/ACC.(18)
(2737) εἰς
for

Line 2523:

ACC.S.N.
ART.(13)
(2738) τὸ
the

Line 2524:

AOR.MID.INF.(50)
(2739) γενέσθαι
to become

Line 2525:

ACC.PL.
2P.PERS.PRO.(19)
(2740) ὑμᾶς
you

Line 2526:

DAT.S.M.
ADJ.(17)
(2741) ἑτέρῳ, =
to another,

Line 2527:

DAT.S.M.
ART.(13)
= (2742) τῷ
to the One

Line 2528:

PREP. GEN.PL.M.
W/GEN.(18) ADJ.(17)
(2743) ἐκ (2744) νεκρῶν
out of dead

Line 2529:

DAT.S.M.
AOR.PASS.PART.(45)
(2745) ἐγερθέντι,
having been raised,

Line 2530:

CONJ.
(2746) ἵνα
in order that

Line 2531:

1P.PL.
AOR.ACT.SUBJ.(48)
(2747) καρποφορήσωμεν
we might bear fruit

Line 2532:

DAT.S.M.
ART.(13)
(2748) τῷ
the

Line 2533:

DAT.S.M.
2DEC.N.(12)
(2749) Θεῷ.
to God.

(2737) **εἰς** - preposition used with the accusative = to, unto, towards

(2738) **ὁ** - article = the

(2739) **γίνομαι** = to become

(2740) **σύ** - second person personal pronoun = you

(2741) **ἕτερος** - adjective = the other, another

(2742) **ὁ** - article = the

(2743) **ἐκ** - preposition used with the genitive = out of, from

(2744) **νεκρός** - adjective = a dead one
from **νεκύς** = a corpse, a dead body

(2745) **ἐγείρω** = rise, raise, to arouse, cause to rise
from **ἀγορά** = an assembly

(2746) **ἵνα** - conjunction = that, in order that

(2747) **καρποφορέω** = to bear or bring forth fruit
from **καρποφόρος** = fruit bearing, productive
from **καρπός** = fruit
and **φέρω** = to carry

(2748) **ὁ** - article = the

(2749) **θεός** = God, deity

Romans 7:5 ὅτε γὰρ ἡμεν ἐν τῇ σαρκί, τὰ παθήματα τῶν ἁμαρτιῶν τὰ διὰ τοῦ νόμου ἐνηργεῖτο ἐν τοῖς μέλεσιν ἡμῶν εἰς τὸ καρποφορῆσαι τῷ θανάτῳ·

Romans 7:5 Diagram

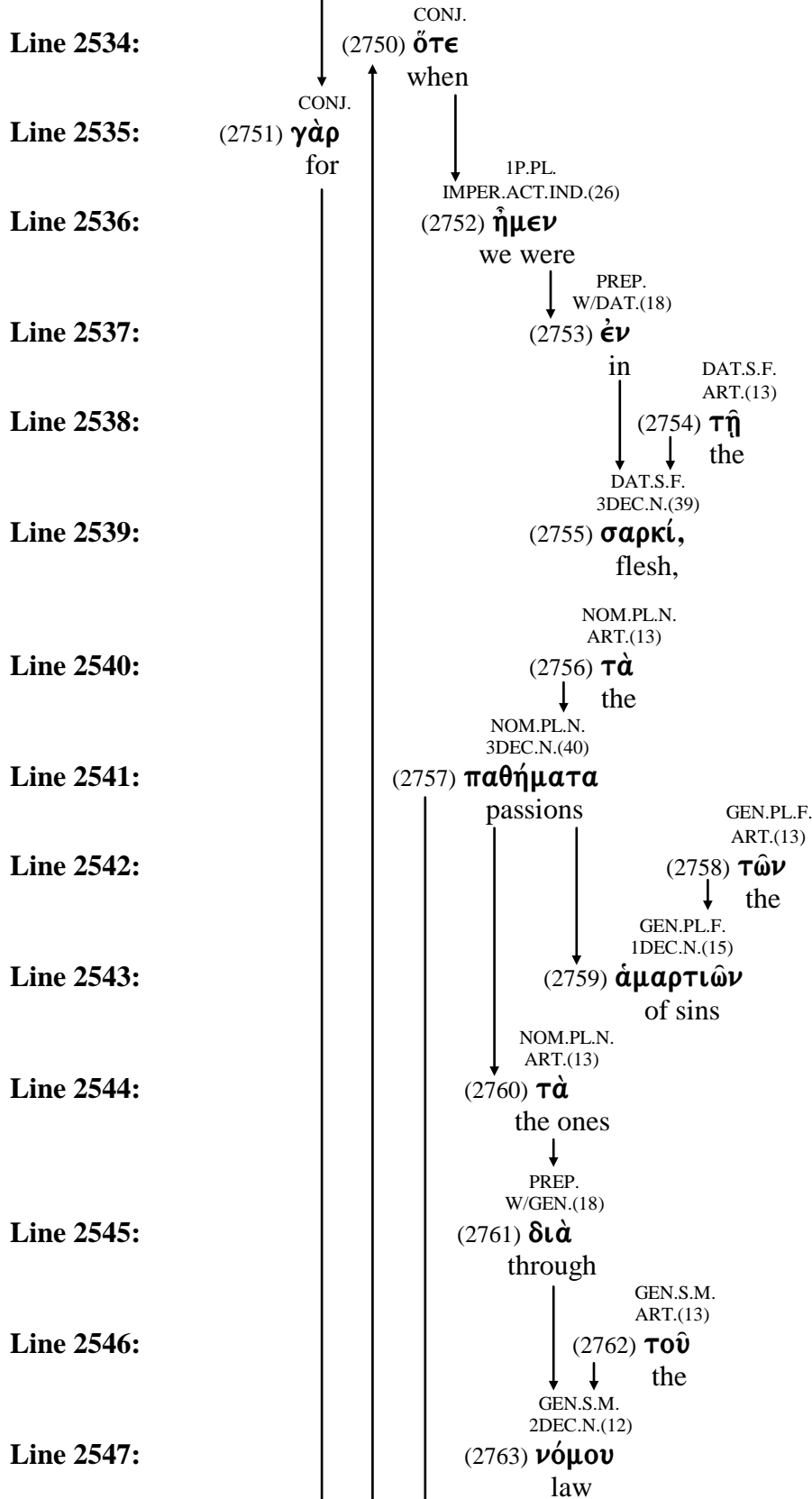

- (2750) **ὅτε** - conjunction = when
from **ὅς** - relative pronoun = who, which, what
- (2751) **γάρ** - conjunction = for
- (2752) **εἰμί** = to be, exist
- (2753) **ἐν** - preposition used with the dative = in
- (2754) **ὁ** - article = the
- (2755) **σάρξ** = flesh
- (2756) **ὁ** - article = the
- (2757) **πάθημα** = passion, suffering
from **πάθος** = passion, affection
from **πάσχω** = suffer, passion
- (2758) **ὁ** - article = the
- (2759) **ἁμαρτία** = to miss the mark
from **ἁμαρτάνω** = to sin, to trespass
- (2760) **ὁ** - article = the
- (2761) **διὰ** - preposition used with the genitive = through
- (2762) **ὁ** - article = the
- (2763) **νόμος** = a law, a command, anything established

Romans 7:5 ὅτε γὰρ ἡμεν ἐν τῇ σαρκί, τὰ παθήματα τῶν ἁμαρτιῶν τὰ διὰ τοῦ νόμου ἐνηργεῖτο ἐν τοῖς μέλεσιν ἡμῶν εἰς τὸ καρποφορῆσαι τῷ θανάτῳ·

Romans 7:5 Diagram

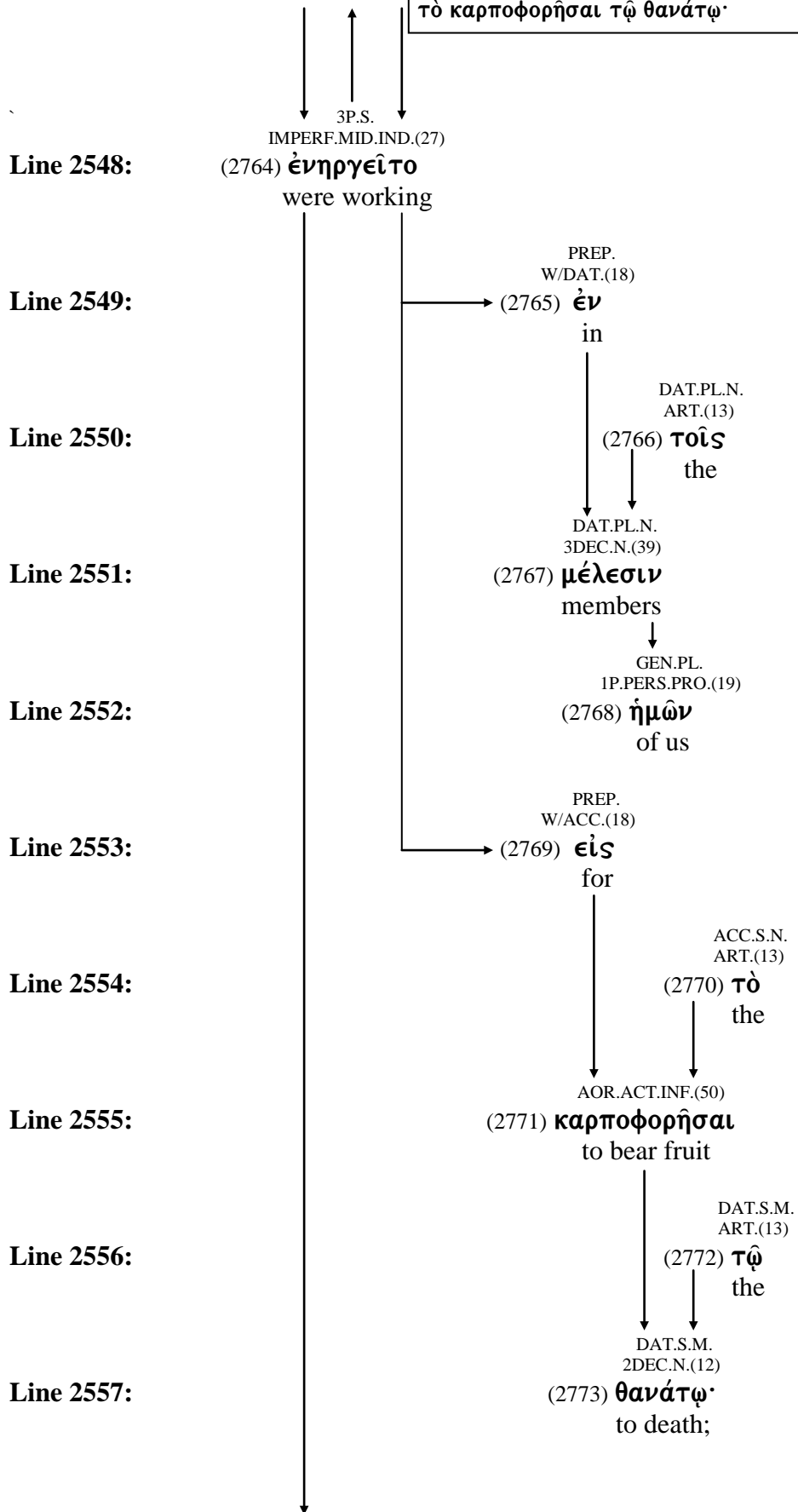

- (2764) **ἐνεργέω** = to energize, to work, to exercise power
from **ἐνεργής** = energy, active
from **ἐν** - preposition = in
and **ἔργον** = work, labor
- (2765) **ἐν** - preposition used with the dative = in
- (2766) **ὁ** - article = the
- (2767) **μέλος** = a member, limb, any part of the body
- (2768) **ἐγώ** - first person personal pronoun = I
- (2769) **εἰς** - preposition used with the accusative = to, unto, towards
- (2770) **ὁ** - article = the
- (2771) **καρποφορέω** = to bear or bring forth fruit
from **καρποφόρος** = fruit bearing, productive
from **καρπός** = fruit
and **φέρω** = to carry
- (2772) **ὁ** - article = the
- (2773) **θάνατος** = death
from **θνήσκω** = to die

Romans 7:6 νυνὶ δὲ κατηργήθημεν ἀπὸ τοῦ νόμου, ἀποθανόντες ἐν ᾧ κατειχόμεθα, ὥστε δουλεύειν ἡμᾶς ἐν καινότητι πνεύματος, καὶ οὐ παλαιότητι γράμματος.

Romans 7:6 Diagram

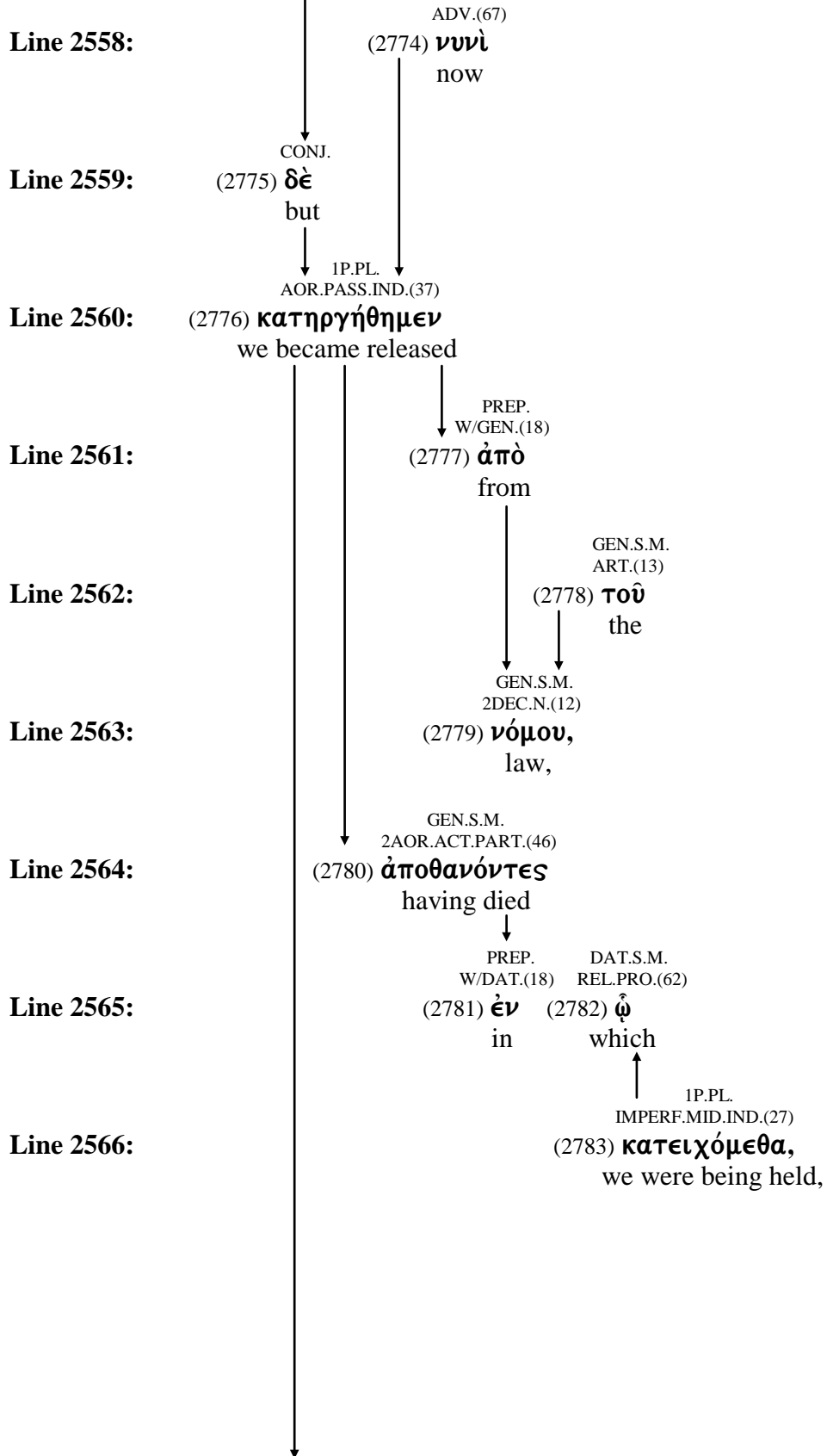

(2774) **νυνί** - adverb, a prolonged form of **νῦν** for emphasis = now, at this present time

(2775) **δέ** - conjunction = and, now, even

(2776) **καταργέω** = to make inactive or inoperative
from **κατά** - preposition = against, down
and **ἀργέω** = to be idle, inactive
from **ἀργός** - adjective = idle, without work
from **α** as a negative particle
and **ἔργον** = to work

(2777) **ἀπό** - preposition used with the genitive = from, out of

(2778) **ὁ** - article = the

(2779) **νόμος** = a law, a command, anything established

(2780) **ἀποθνήσκω** = to die
from **ἀπό** - preposition = from
and **θνήσκω** = to be dead

(2781) **ἐν** - preposition used with the dative = in

(2782) **ὅς** - relative pronoun = who, which, what

(2783) **κατέχω** = to hold, possess, to take
from **κατά** - preposition used with the genitive = down, against
and **ἔχω** = to have, to hold

Romans 7:6 Diagram

Romans 7:6 νυνὶ δὲ κατηργήθημεν ἀπὸ τοῦ νόμου, ἀποθανόντες ἐν ᾧ κατειχόμεθα, ὥστε δουλεύειν ἡμᾶς ἐν καινότητι πνεύματος, καὶ οὐ παλαιότητι γράμματος.

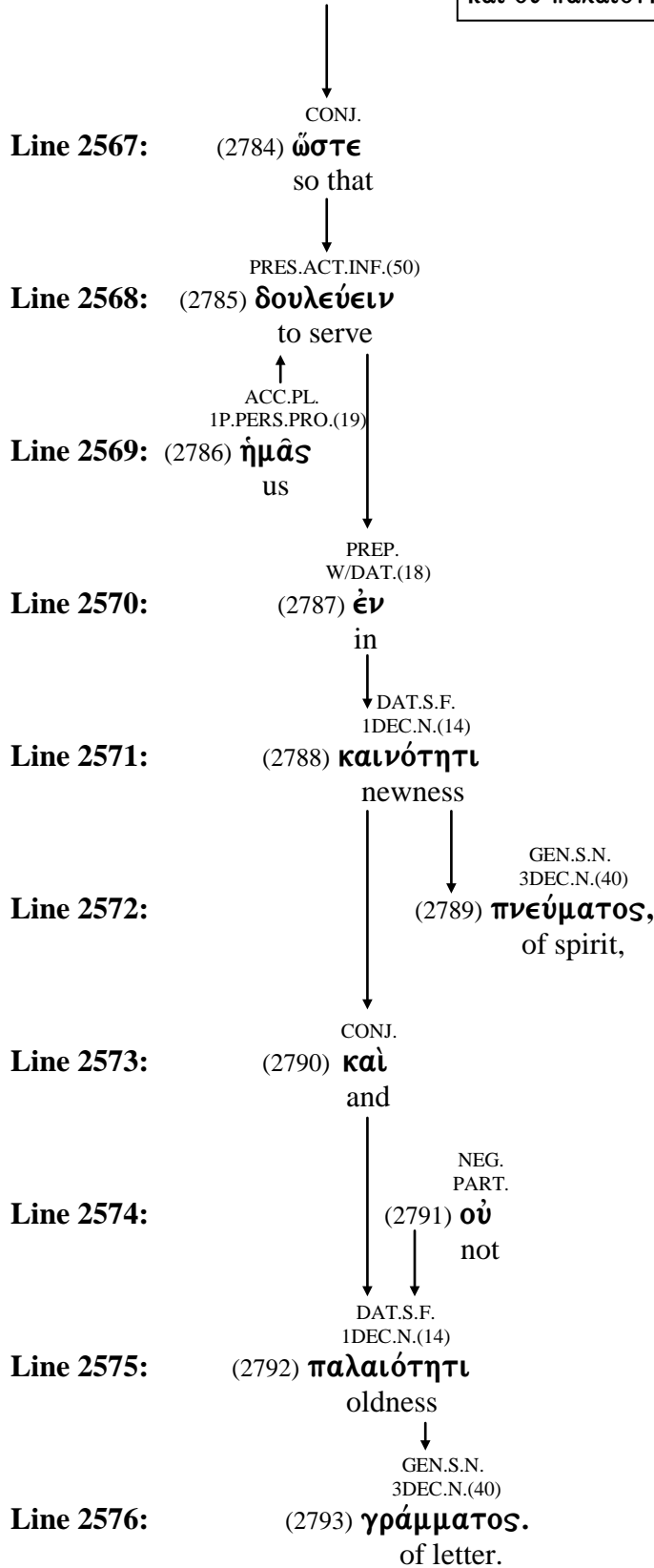

- (2784) **ὥστε** - conjunction = so that, so then, insomuch that
from **ὡς** - adverb = as, like
and **τέ** - particle = and, even, also
- (2785) **δουλεύω** = to serve, to serve as a slave; to be in bondage
from **δοῦλος** = a servant, a slave
from **δέω** = to bind, to fasten
- (2786) **ἐγώ** - first person personal pronoun = I
- (2787) **ἐν** - preposition used with the dative = in
- (2788) **καινότης** = newness
from **καινός** - adjective = new
- (2789) **πνεῦμα** = spirit, wind
from **πνέω** = to breathe, to blow
- (2790) **καί** - conjunction = and, also, even
- (2791) **οὐ** - negative particle = no, not
- (2792) **παλαίος** = old, not new or recent
from **πάλαι** - adverb = old, former, long ago
- (2793) **γράμμα** = letter of the alphabet, document, something written
from **γράφω** = to write

