

# Lesson Twenty-Three

## Romans 6:8-14

- 8) εἰ δὲ ἀπεθάνομεν σὺν Χριστῷ, πιστεύομεν ὅτι καὶ συζήσομεν  
if and we died with Christ, we believe that also we will live with

αὐτῷ·  
Him;

- 9) εἰδότες ὅτι Χριστὸς ἐγερθεὶς ἐκ νεκρῶν οὐκέτι  
knowing that Christ having been raised out of dead no longer

ἀποθνήσκει· θάνατος αὐτοῦ οὐκέτι κυριεύει.  
He is dying; death Him no longer is lording over.

- 10) ὃ γὰρ ἀπέθανε(ν), τῇ ἁμαρτίᾳ ἀπέθανεν ἐφάπαξ· ὃ δὲ  
what for He died, the to sin He died once; what and

ζῆ, ζῆ τῷ Θεῷ.  
He is living, He is living the to God.

- 11) οὕτω(ς) καὶ ὑμεῖς λογίζεσθε ἑαυτοὺς (εἶναι) νεκροὺς μὲν  
in this way also yourselves you be imputing yourselves (to be) dead indeed

εἶναι τῇ ἁμαρτίᾳ, ζῶντας δὲ τῷ Θεῷ ἐν Χριστῷ Ἰησοῦ [τῷ  
to be the to sin, living and the to God in Christ Jesus [the

Κυρίῳ ἡμῶν].  
Lord of us].

12) Μὴ οὖν βασιλεύτω ἡ ἁμαρτία ἐν τῷ θνητῷ ὑμῶν σώματι,  
Not therefore let reign the sin in the mortal of you body,

εἰς τὸ ὑπακούειν [αὐτῇ ἐν] ταῖς ἐπιθυμίαις αὐτοῦ·  
for the to obey [it in] the lusts of it;

13) μηδὲ παριστάνετε τὰ μέλη ὑμῶν ὄπλα ἀδικίας τῇ  
neither be presenting the members of you instruments of unrighteousness the

ἁμαρτία· ἀλλὰ παραστήσατε ἑαυτοὺς τῷ Θεῷ ὡσεὶ ἐκ νεκρῶν  
to sin; but present yourselves the to God as if out of dead

ζῶντας, καὶ τὰ μέλη ὑμῶν ὄπλα δικαιοσύνης τῷ Θεῷ.  
living, and the members of you instruments of righteousness the to God.

14) ἁμαρτία γὰρ ὑμῶν οὐ κυριεύσει· οὐ γὰρ ἐστε ὑπὸ νόμον,  
sin for you not will lord over; not for you are under law,

ἀλλὰ ὑπὸ χάριν.  
but under grace.

**Word Association Diagram**

Romans 6:8-14

**VERSE 8**

Line 2191:

Line 2192:

Line 2193:

Line 2194:

Line 2195:

Line 2196:

Line 2197:

Line 2198:

Line 2199:

**VERSE 9**

Line 2200:

Line 2201:

Line 2202:

Line 2203:

Line 2204:

Line 2205:

Line 2206:

Line 2207:

Line 2208:

Line 2209:

Line 2210:

**VERSE 10**

Line 2211:

Line 2212:

Line 2213:

Line 2214:

Line 2215:

Line 2216:

Line 2217:

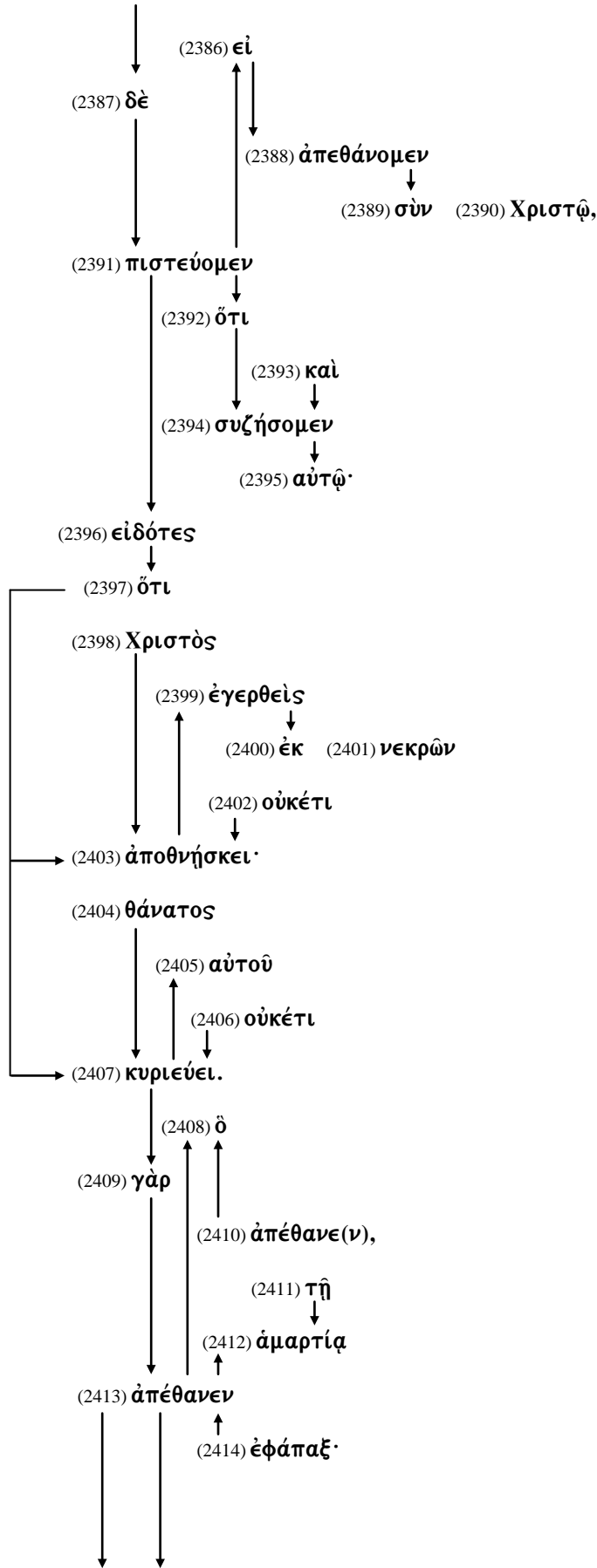

VERSE 10 (continued)

Line 2218:

Line 2219:

Line 2220:

Line 2221:

Line 2222:

Line 2223:

VERSE 11

Line 2224:

Line 2225:

Line 2226:

Line 2227:

Line 2228:

Line 2229:

Line 2230:

Line 2231:

Line 2232:

Line 2233:

Line 2234:

Line 2235:

Line 2236:

Line 2237:

Line 2238:

Line 2239:

Line 2240:

Line 2241:

Line 2242:

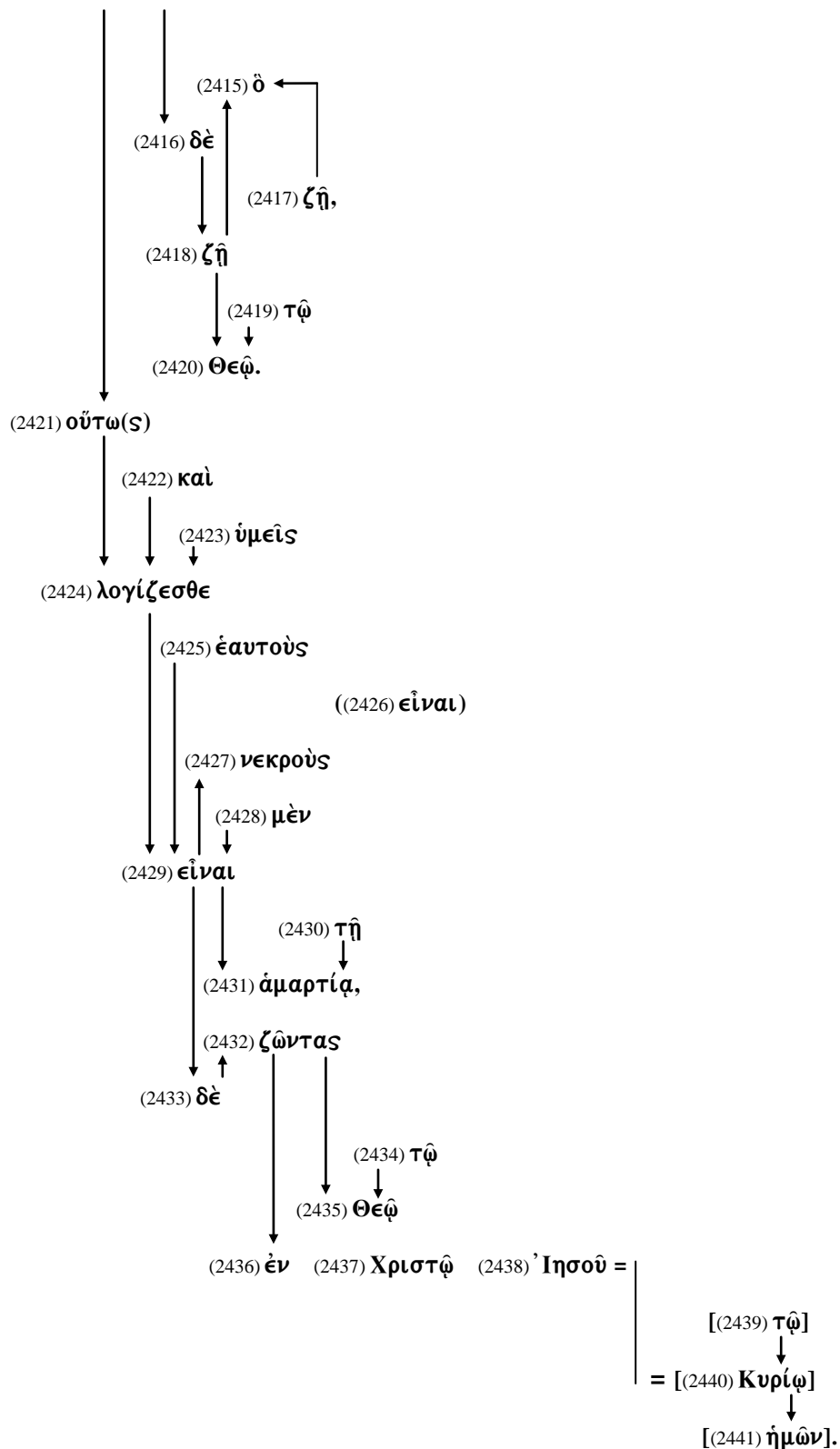

**Word Association Diagram**

Romans 6:8-14

**VERSE 12**

Line 2243:

(2442) Μή

Line 2244:

(2443) οὖν

Line 2245:

(2444) βασιλευέτω

Line 2246:

(2445) ἥ

Line 2247:

(2446) ἀμαρτία

Line 2248:

(2447) ἐν

Line 2249:

(2448) τῷ

Line 2250:

(2449) θνητῷ

Line 2251:

(2450) ὑμῶν

Line 2252:

(2451) σώματι,

Line 2253:

(2452) εἰς

Line 2254:

(2453) τὸ

Line 2255:

(2454) ὑπακούειν

Line 2256:

[(2455) αὐτῇ]

Line 2257:

[(2456) ἐν]

Line 2258:

(2457) ταῖς

Line 2259:

(2458) ἐπιθυμίαις

Line 2260:

(2459) αὐτοῦ·

**VERSE 13**

Line 2261:

(2460) μηδὲ

Line 2262:

(2461) παριστάνετε

Line 2263:

(2462) τὰ

Line 2264:

(2463) μέλη

Line 2265:

(2464) ὑμῶν

Line 2266:

(2465) ὅπλα

Line 2267:

(2466) ἀδικίας

Line 2268:

(2467) τῇ

Line 2269:

(2468) ἀμαρτία·

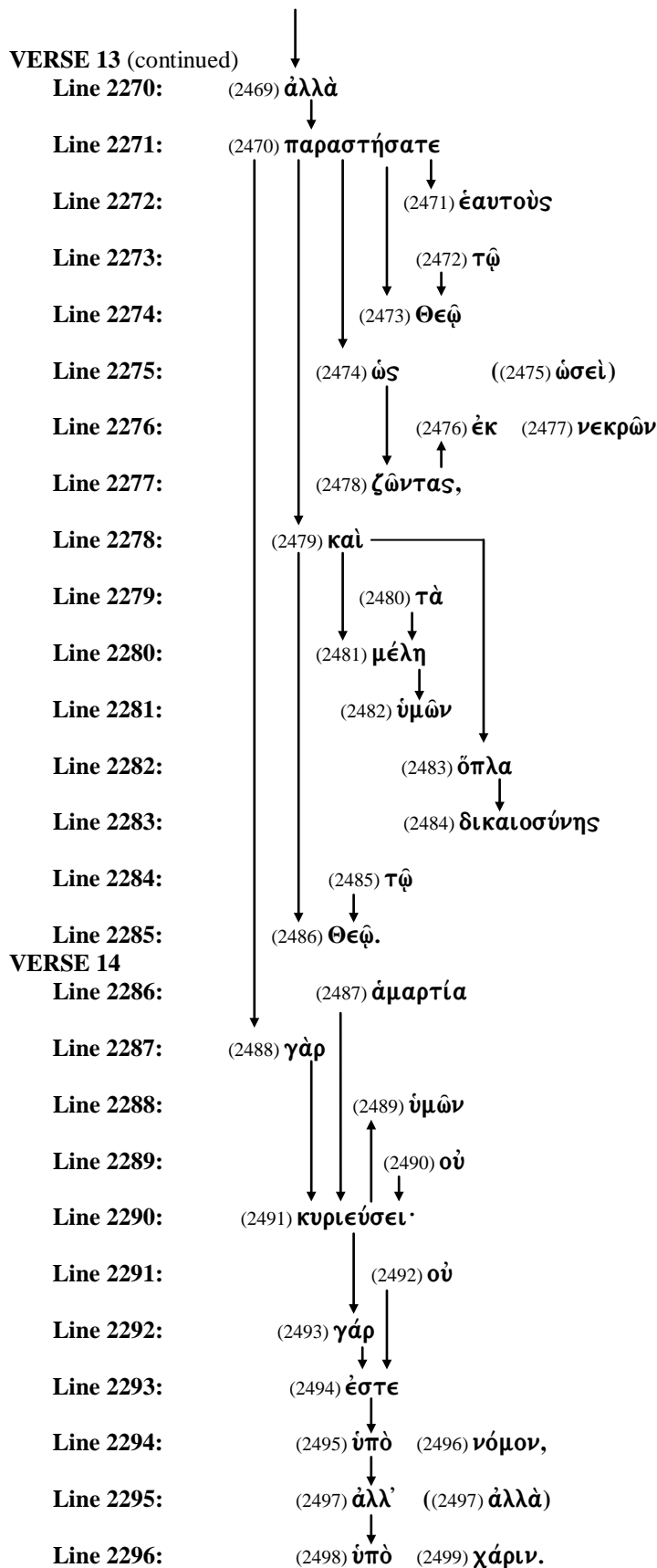

**I Romans 1:1-17**  
The Introduction

**II Romans 1:18-11:36**  
The Doctrine of the Christian Faith

**Romans 1:18-3:20**  
The Indictment: The Doctrine of Condemnation

**Romans 3:21-5:21**  
The Imputation: The Doctrine of Justification

**Romans 6:1-8:39**  
The Impartation: The Doctrine of Sanctification

**Romans chapters 6-7 are systematically arranged around four questions:**

- 1) **Romans 6:1**
- 2) **Romans 6:15**
- 3) **Romans 7:7**
- 4) **Romans 7:13**

**Romans 6 The Power over Sin**  
**Romans 6:1-14** The Principles of Sanctification  
**Romans 6:15-23** The Process of Sanctification

**Romans 7 The Problem of the Flesh**  
**Romans 7:1-6** The Precepts of Sanctification  
**Romans 7:7-13** The Perception of Sanctification  
**Romans 7:14-25** The Performance of Sanctification

**Romans 8 The Provision of the Spirit**  
**Romans 8:1-4** The Plan of Sanctification  
**Romans 8:5-11** The Procedure of Sanctification  
**Romans 8:12-17** The Product of Sanctification  
**Romans 8:18-25** The Patience in Sanctification  
**Romans 8:26-30** The Provision of Sanctification  
**Romans 8:31-39** The Position in Sanctification



# Lesson Twenty-Three

## Romans 6:8-14

### Diagrams

Romans 6:8 εἰ δὲ ἀπεθάνομεν σὺν Χριστῷ, πιστεύομεν ὅτι καὶ συζήσομεν αὐτῷ·

Romans 6:8 Diagram

Line 2191:

CONJ.  
(2386) εἰ  
if

Line 2192:

CONJ.  
(2387) δὲ  
and

Line 2193:

1P.PL.  
2AOR.ACT.IND.(35)  
(2388) ἀπεθάνομεν  
we died

Line 2194:

PREP.                      DAT.S.M.  
W/DAT.(18)                2DEC.N.(12)  
(2389) σὺν                (2390) Χριστῷ,  
with                              Christ,

Line 2195:

1P.PL.  
PRES.ACT.IND.(10)  
(2391) πιστεύομεν  
we believe

Line 2196:

CONJ.  
(2392) ὅτι  
that

Line 2197:

CONJ.  
(2393) καὶ  
also

Line 2198:

1P.PL.  
FUT.ACT.IND.(31)  
(2394) συζήσομεν  
we will live with

Line 2199:

DAT.S.M.  
3P.PERS.PRO.(20)  
(2395) αὐτῷ·  
Him;

(2386) **εἰ** - conjunction = if

(2387) **δὲ** - conjunction = and, now, even

(2388) **ἀποθνήσκω** = to die  
from **ἀπό** - preposition = from  
and **θνήσκω** = to be dead

(2389) **σύν** - preposition used with the dative = with, together

(2390) **Χριστός** = Christ  
meaning “anointed” - from **χρίω** = to anoint

(2391) **πιστεύω** = to believe, to be persuaded  
from **πίστις** = faith  
from **πείθω** = to persuade

(2392) **ὅτι** - conjunction = that, because

(2393) **καί** - conjunction = and, also, even

(2394) **συζάω** = to live with  
from **σύν** - preposition = with  
and **ζάω** = to live

(2395) **αὐτός** - third person personal pronoun = he, she, it

Romans 6:9 Diagram

**Romans 6:9** εἰδότες ὅτι Χριστὸς ἐγερθεὶς ἐκ νεκρῶν οὐκέτι ἀποθνήσκει· θάνατος αὐτοῦ οὐκέτι κυριεύει.

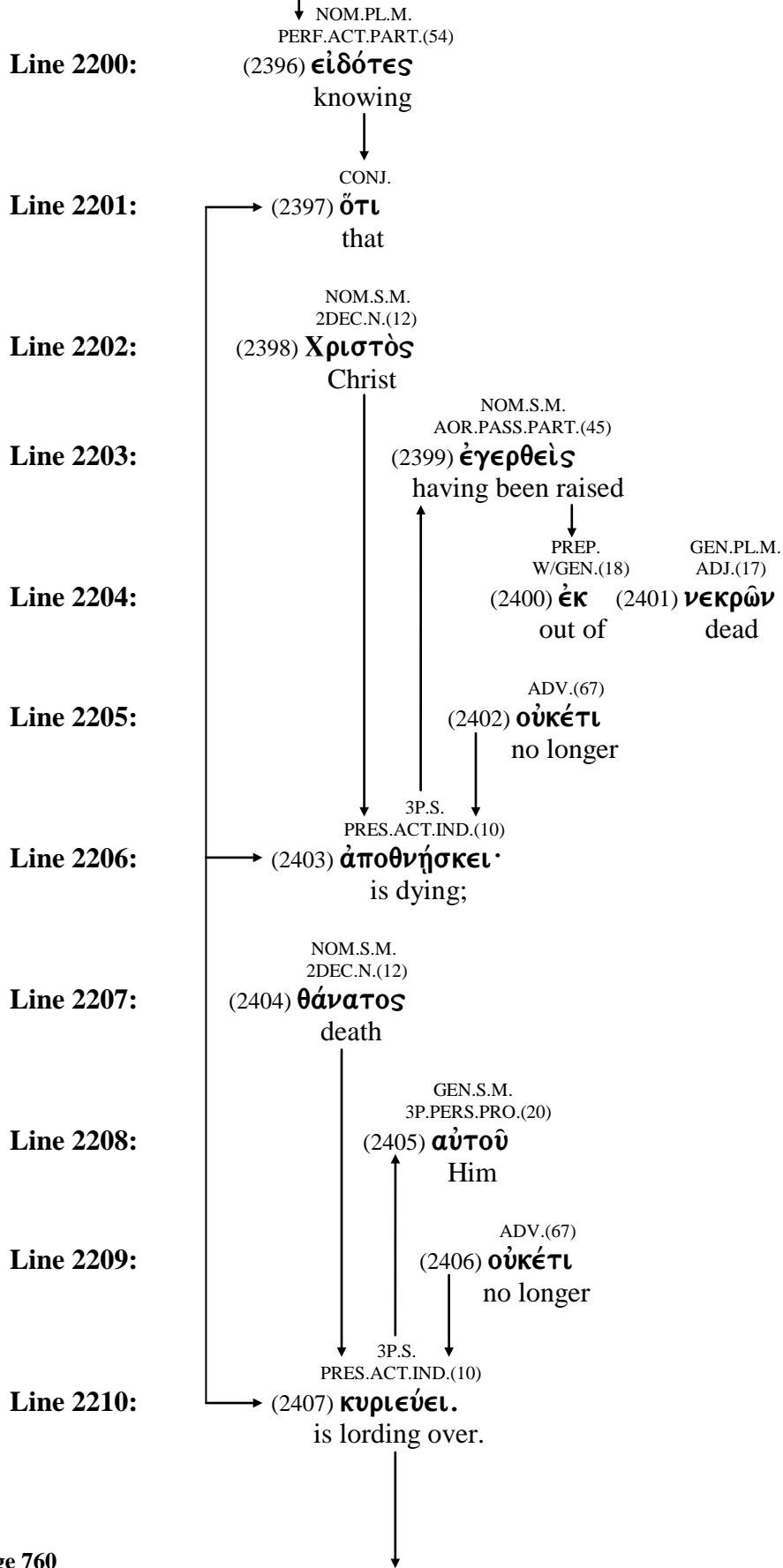

- (2396) **οἶδα** = to see, to perceive with the eyes; to perceive with the senses
- (2397) **ὅτι** - conjunction = that, because
- (2398) **Χριστός** = Christ  
meaning “anointed” - from **χρίω** = to anoint
- (2399) **ἐγείρω** = rise, raise, to arouse, cause to rise  
from **ἀγορά** = an assembly
- (2400) **ἐκ** - preposition used with the genitive = out of, from
- (2401) **νεκρός** - adjective = a dead one  
from **νεκός** = a corpse, a dead body
- (2402) **οὐκέτι** - adverb = not yet, no longer  
from **οὐ** - negative particle = no, not  
and **ἔτι** - adverb = still, yet, longer  
from **ἔτος** = a year
- (2403) **ἀποθνήσκω** = to die  
from **ἀπό** - preposition = from  
and **θνήσκω** = to be dead
- (2404) **θάνατος** = death  
from **θνήσκω** = to die
- (2405) **αὐτός** - third person personal pronoun = he, she, it
- (2406) **οὐκέτι** - adverb = not yet, no longer  
from **οὐ** - negative particle = no, not  
and **ἔτι** - adverb = still, yet, longer  
from **ἔτος** = a year
- (2407) **κυριεύω** = to lord or ruler over  
from **κύριος** = lord, master

Romans 6:10 Diagram

**Romans 6:10** ὁ γὰρ ἀπέθανε(ν), τῇ ἀμαρτίᾳ ἀπέθανεν ἐφάπαξ· ὁ δὲ ζῆ, ζῆ τῷ Θεῷ.

Line 2211:

ACC.S.N.  
REL.PRO.(62)  
(2408) ὃ  
what

Line 2212:

CONJ.  
(2409) γὰρ  
for

Line 2213:

3P.S.  
2AOR.ACT.IND.(35)  
(2410) ἀπέθανε(ν),  
He died,

Line 2214:

DAT.S.F.  
ART.(13)

(2411) τῇ  
the

Line 2215:

DAT.S.F.  
1DEC.N.(15)

(2412) ἀμαρτία  
to sin

Line 2216:

3P.S.  
2AOR.ACT.IND.(35)

(2413) ἀπέθανεν  
He died

Line 2217:

ADV.(67)

(2414) ἐφάπαξ·  
once for all;

Line 2218:

ACC.S.N.  
REL.PRO.(62)

(2415) ὃ  
what

Line 2219:

CONJ.  
(2416) δὲ  
and

Line 2220:

3P.S.  
PRES.ACT.IND.(10)

(2417) ζῆ,  
He is living,

Line 2221:

3P.S.  
PRES.ACT.IND.(10)

(2418) ζῆ  
He is living

Line 2222:

DAT.S.M.  
ART.(13)

(2419) τῷ  
the

Line 2223:

DAT.S.M.  
2DEC.N.(12)

(2420) Θεῷ.  
to God.

- (2408) **ὅς** - relative pronoun = who, which, what
- (2409) **γάρ** - conjunction = for
- (2410) **ἀποθνήσκω** = to die  
from **ἀπό** - preposition = from  
and **θνήσκω** = to be dead
- (2411) **ὁ** - article = the
- (2412) **ἁμαρτία** = to miss the mark  
from **ἁμαρτάνω** = sin, trespass
- (2413) **ἀποθνήσκω** = to die  
from **ἀπό** - preposition = from  
and **θνήσκω** = to be dead
- (2414) **ἐφάπαξ** - adverb = at once, once and for all  
from **ἐπί** - preposition = upon, over  
and **ἅπαξ** - adverb = once  
from **ἅπας** - adjective = all, every, whole  
from **α** - a particle of union = with  
and **πᾶς** - adjective = all, every, whole
- (2415) **ὅς** - relative pronoun = who, which, what
- (2416) **δὲ** - conjunction = and, now, even
- (2417) **ζάω** = to live, to breathe
- (2418) **ζάω** = to live, to breathe
- (2419) **ὁ** - article = the
- (2420) **θεός** = God, deity

Romans 6:11 Diagram

**Romans 6:11** οὕτω(ς) καὶ ὑμεῖς λογίζεσθε ἑαυτοὺς (εἶναι) νεκροὺς μὲν εἶναι τῇ ἁμαρτία, ζῶντας δὲ τῷ Θεῷ ἐν Χριστῷ Ἰησοῦ [τῷ Κυρίῳ ἡμῶν].

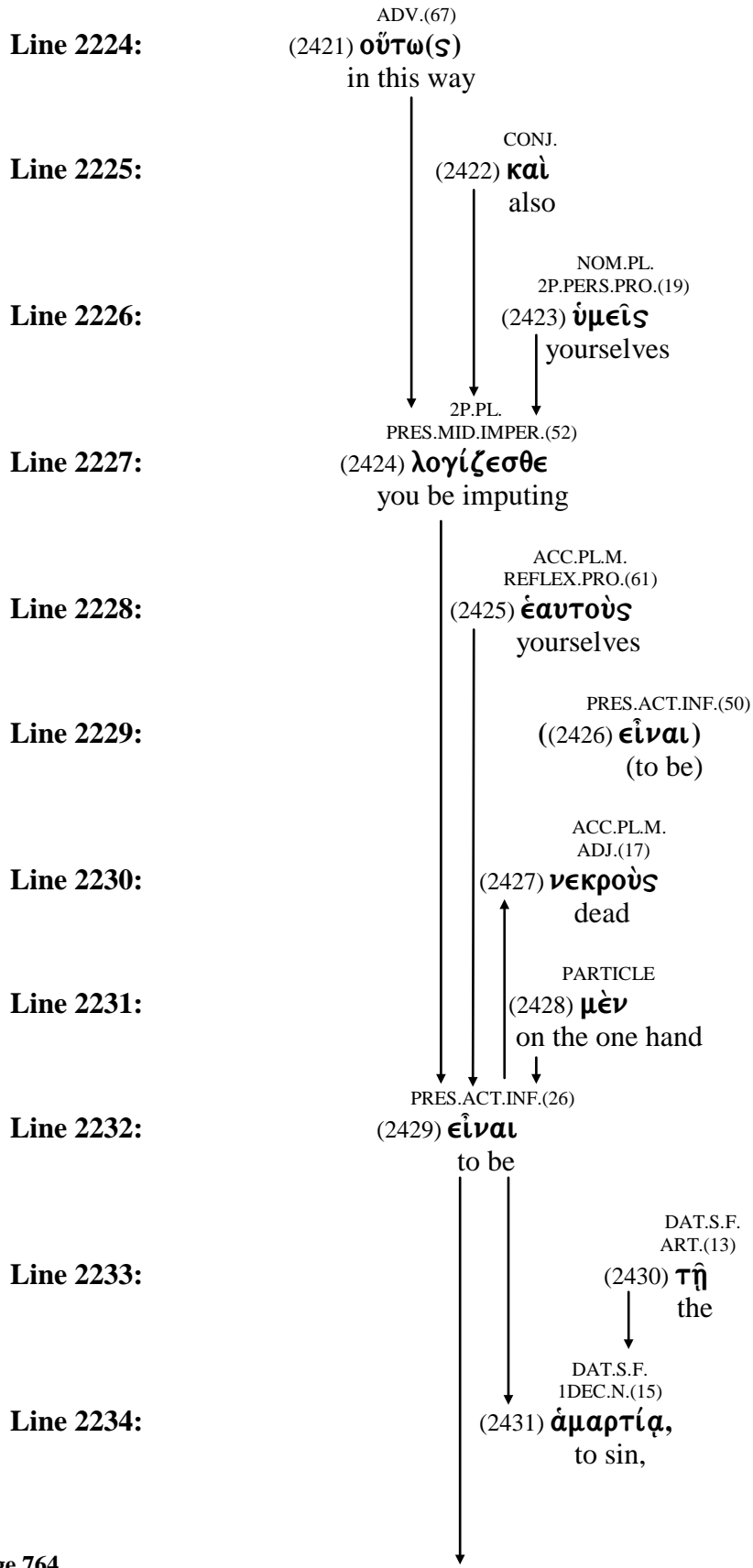



- (2421) **οὕτως** - adverb = so, thus, in this manner  
from **οὗτος** - demonstrative pronoun = this
- (2422) **καί** - conjunction = and, also, even
- (2423) **σύ** - second person personal pronoun = you
- (2424) **λογίζομαι** = to reckon, count, compute, calculate  
from **λόγος** = word, saying, account
- (2425) **ἑαυτοῦ** - reflexive pronoun = himself  
from **αὐτός** - third person personal pronoun = he, she, it
- (2426) **εἰμί** = to be, exist
- (2427) **νεκρός** - adjective = a dead one  
from **νεκύς** = a corpse, a dead body
- (2428) **μέν** - particle = truly, certainly, indeed
- (2429) **εἰμί** = to be, exist
- (2430) **ὁ** - article = the
- (2431) **ἁμαρτία** = to miss the mark  
from **ἁμαρτάνω** = sin, trespass

Romans 6:11 Diagram

**Romans 6:11** οὕτω(ς) καὶ ὑμεῖς λογίζεσθε ἑαυτοὺς (εἶναι) νεκροὺς μὲν εἶναι τῇ ἁμαρτία, ζῶντας δὲ τῷ Θεῷ ἐν Χριστῷ Ἰησοῦ [τῷ Κυρίῳ ἡμῶν].

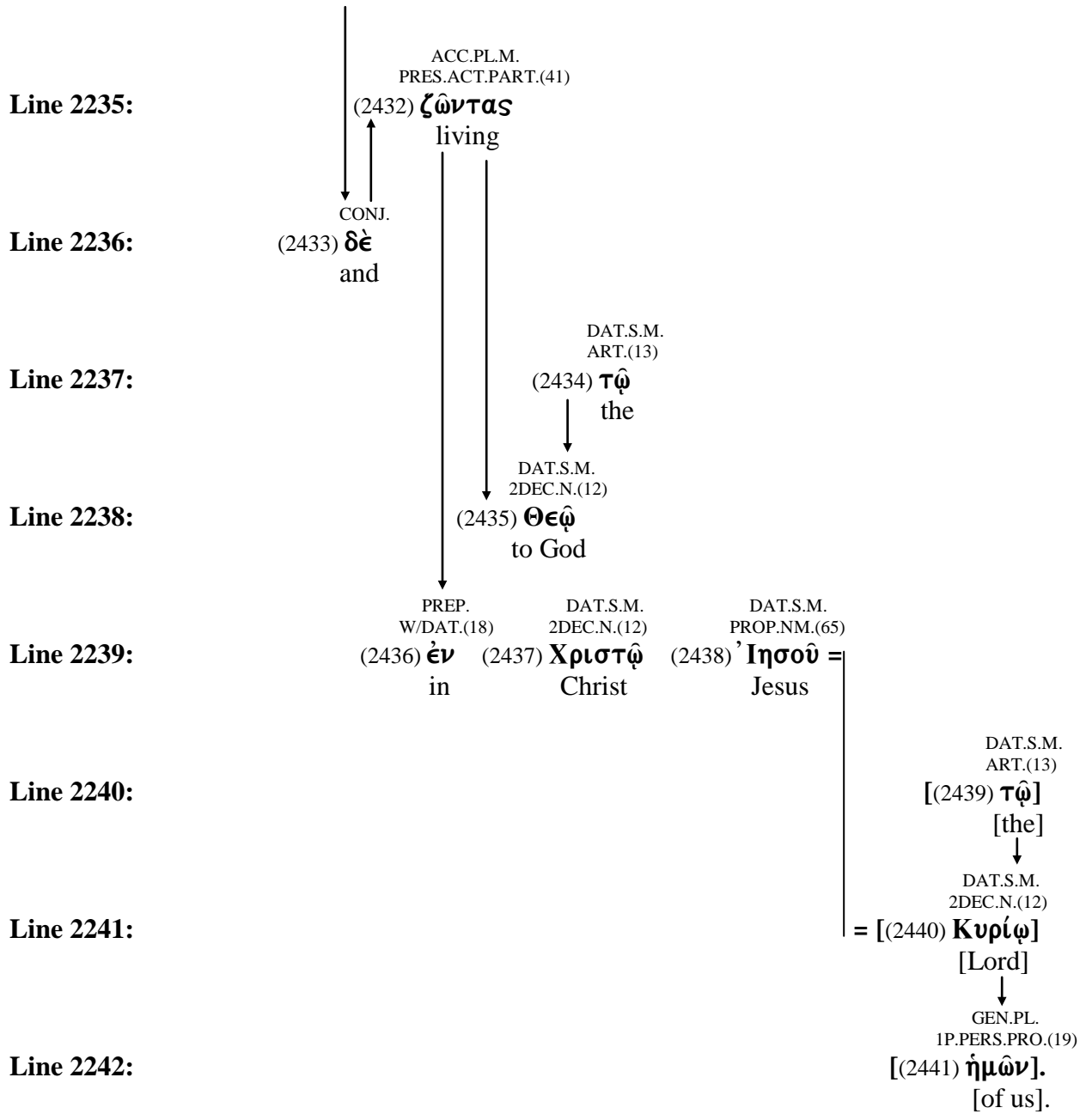

(2432) **ζάω** = to live, to breathe

(2433) **δέ** - conjunction = and, now, even

(2434) **ὁ** - article = the

(2435) **θεός** = God, deity

(2436) **ἐν** - preposition used with the dative = in

(2437) **Χριστός** = Christ  
meaning “anointed” - from **χρίω** = to anoint

(2438) **Ἰησοῦς** = Jesus  
of Hebrew origin - from **יְהוֹשֻׁעַ** = Joshua or Jehoshua = “Yahweh is salvation”  
from **יְהוָה** = Yahweh = “the existing One”  
from **הָיָה** = to be, become, come to  
and **שָׁמַר** = to save, be saved, be delivered, to rescue

(2439) **ὁ** - article = the

(2440) **κύριος** = lord, master  
from **κύρος** = supremacy

(2441) **ἐγώ** - first person personal pronoun = I

Romans 6:12 Diagram

Romans 6:12 Μὴ οὖν βασιλεύτω ἡ ἀμαρτία ἐν τῷ θνητῷ ὑμῶν σώματι, εἰς τὸ ὑπακούειν [αὐτῇ ἐν] ταῖς ἐπιθυμίαις αὐτοῦ·

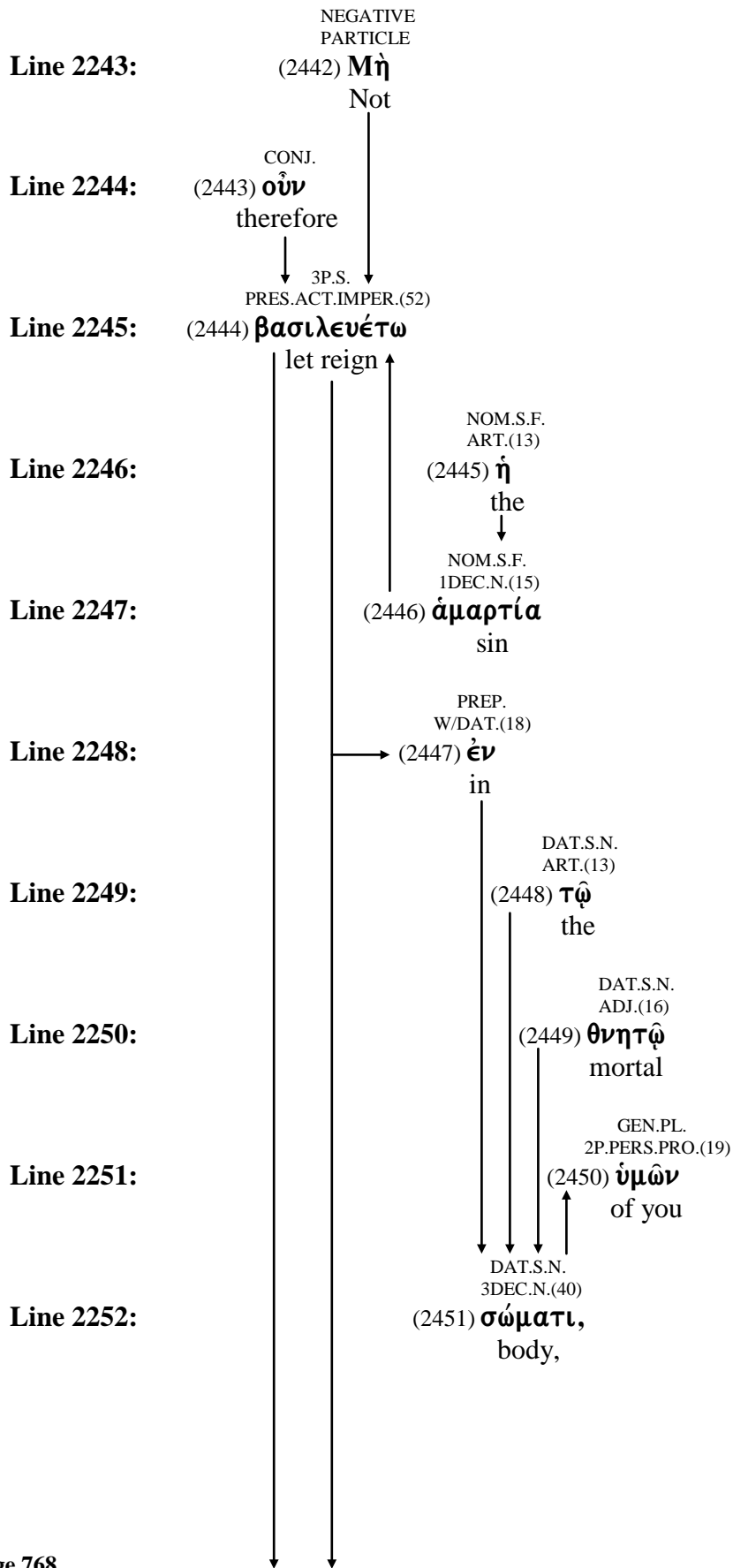

- (2442) μή - negative particle = no, not
- (2443) οὖν - particle = therefore, then
- (2444) βασιλεύω = to reign, to rule  
from βασιλεύς = king  
from βάσις = foot, feet
- (2445) ὁ - article = the
- (2446) ἁμαρτία = to miss the mark  
from ἁμαρτάνω = sin, trespass
- (2447) ἐν - preposition used with the dative = in
- (2448) ὁ - article = the
- (2449) θνητός - adjective = mortal, human, susceptible to death  
from θνήσκω = to die, to become dead
- (2450) σύ - second person personal pronoun = you
- (2451) σῶμα = body

**Romans 6:12** Μὴ οὖν βασιλευέτω ἡ ἁμαρτία ἐν τῷ θνητῷ ὑμῶν  
σώματι, εἰς τὸ ὑπακούειν [αὐτῇ ἐν] ταῖς ἐπιθυμίαις αὐτοῦ·

**Romans 6:12 Diagram**

**Line 2253:**

PREP.  
W/ACC.(18)  
(2452) εἰς  
for

**Line 2254:**

ACC.S.N.  
ART.(13)  
(2453) τὸ  
the

**Line 2255:**

PRES.ACT.INF.(50)  
(2454) ὑπακούειν  
to obey

**Line 2256:**

DAT.S.F.  
3P.PERS.PRO.(20)  
[(2455) αὐτῇ]  
[it]

**Line 2257:**

PREP.  
W/DAT.(18)  
[(2456) ἐν]  
[in]

**Line 2258:**

DAT.PL.F.  
ART.(13)  
(2457) ταῖς  
the

**Line 2259:**

DAT.PL.F.  
1DEC.N.(15)  
(2458) ἐπιθυμίαις  
lusts

**Line 2260:**

GEN.S.N.  
3P.PERS.PRO.(20)  
(2459) αὐτοῦ·  
of it;

(2452) **εἰς** - preposition used with the accusative = to, unto, towards

(2453) **ὁ** - article = the

(2454) **ὑπακούω** = to listen under, to obey, to follow  
from **ὑπό** - preposition = under, by  
and **ἀκούω** = to hear

(2455) **αὐτός** - third person personal pronoun = he, she, it

(2456) **ἐν** - preposition used with the dative = in

(2457) **ὁ** - article = the

(2458) **ἐπιθυμία** = desire, lust  
from **ἐπιθυμέω** = to desire, to long for  
from **ἐπί** - preposition = upon  
and **θυμός** = heat, passion, anger

(2459) **αὐτός** - third person personal pronoun = he, she, it

**Romans 6:13** μηδὲ παριστάνετε τὰ μέλη ὑμῶν ὄπλα ἀδικίας τῇ ἀμαρτίᾳ· ἀλλὰ παραστήσατε ἑαυτοὺς τῷ Θεῷ ὡς (ὡσεὶ) ἐκ νεκρῶν ζῶντας, καὶ τὰ μέλη ὑμῶν ὄπλα δικαιοσύνης τῷ Θεῷ.

**Romans 6:13 Diagram**

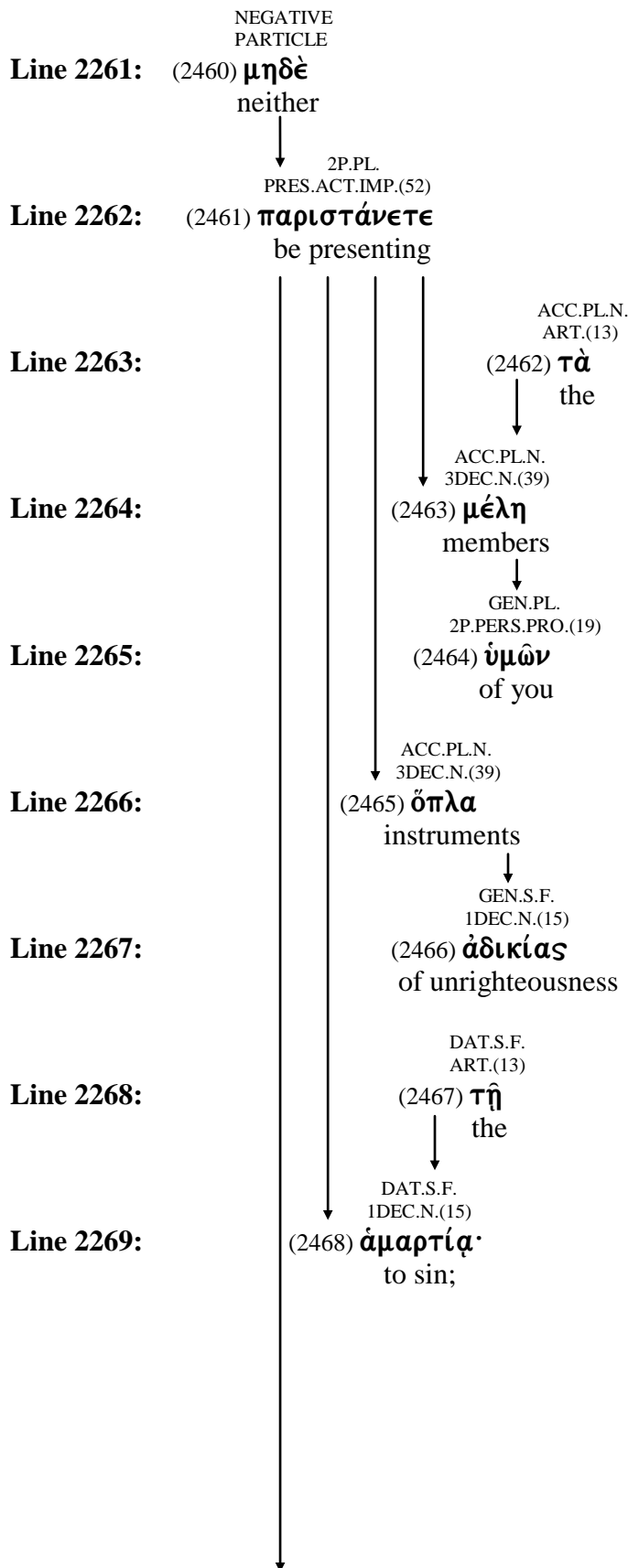



- (2460) **μηδέ** = not even, and not  
from **μή** - negative particle = no, not  
and **δέ** - conjunction = and, now, even
- (2461) **παρίστημι** = to place alongside of, to present  
from **παρά** - preposition = from, along side of, near  
and **ἵστημι** = to place, set, to cause to stand
- (2462) **ὁ** - article = the
- (2463) **μέλος** = a member, limb, any part of the body
- (2464) **σύ** - second person personal pronoun = you
- (2465) **ὄπλον** = a weapon, instrument, tool, armor
- (2466) **ἀδικία** = injustice, wrong, wrongdoing, unrighteous  
from **ἄδικος** - adjective = unjust, unrighteous  
from **α** - a particle of privation = without  
and **δίκη** = justice, punishment  
from **δεικνύω** = to show, to point out
- (2467) **ὁ** - article = the
- (2468) **ἁμαρτία** = to miss the mark  
from **ἁμαρτάνω** = sin, trespass

**Romans 6:13** μηδὲ παριστάνετε τὰ μέλη ὑμῶν ὄπλα ἀδικίας τῇ ἀμαρτία· ἀλλὰ παραστήσατε ἑαυτοὺς τῷ Θεῷ ὡς (ὡσεὶ) ἐκ νεκρῶν ζῶντας, καὶ τὰ μέλη ὑμῶν ὄπλα δικαιοσύνης τῷ Θεῷ.

**Romans 6:13 Diagram**

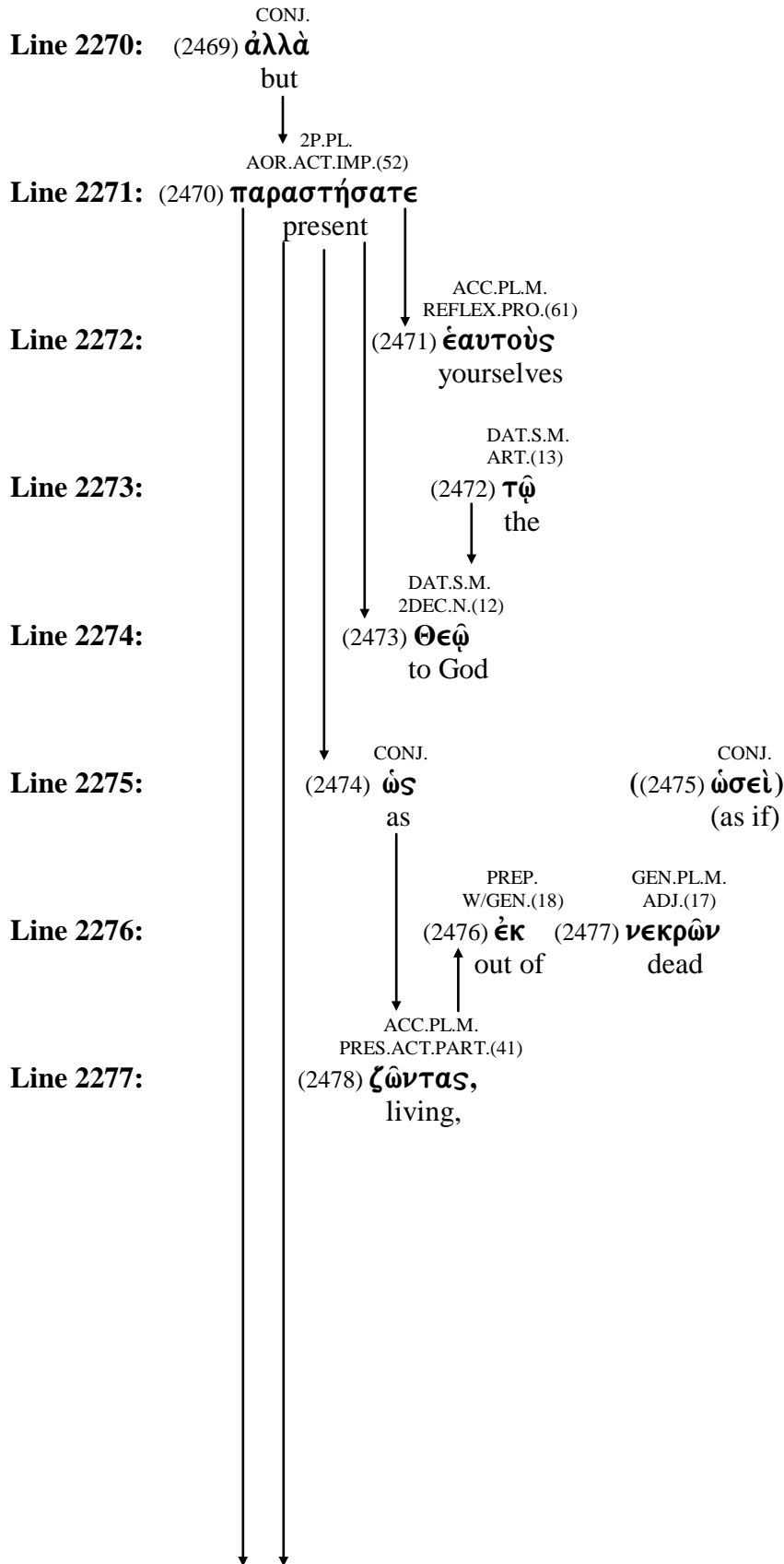

- (2469) **ἀλλά** - conjunction = but
- (2470) **παρίστημι** = to stand beside, to present  
from **παρά** - preposition = alongside  
and **ἵστημι** = to stand
- (2471) **ἑαυτοῦ** - reflexive pronoun = himself  
from **αὐτός** - third person personal pronoun = he, she, it
- (2472) **ὁ** - article = the
- (2473) **θεός** = God, deity
- (2474) **ὡς** - adverb used as a comparative particle = as, like  
from **ὅς** - relative pronoun = who, which, what
- (2475) **ὡσεὶ** - adverb = as if  
from **ὡς** - adverb = as, like  
and **εἰ** - conjunction = if
- (2476) **ἐκ** - preposition used with the genitive = out of, from
- (2477) **νεκρός** - adjective = a dead one  
from **νεκός** = a corpse, a dead body
- (2478) **ζάω** = to be alive, to live

**Romans 6:13** μηδὲ παριστάνετε τὰ μέλη ὑμῶν ὄπλα ἀδικίας τῇ ἀμαρτία· ἀλλὰ παραστήσατε ἑαυτοὺς τῷ Θεῷ ὡς (ὡσεὶ) ἐκ νεκρῶν ζῶντας, καὶ τὰ μέλη ὑμῶν ὄπλα δικαιοσύνης τῷ Θεῷ.

**Romans 6:13 Diagram**

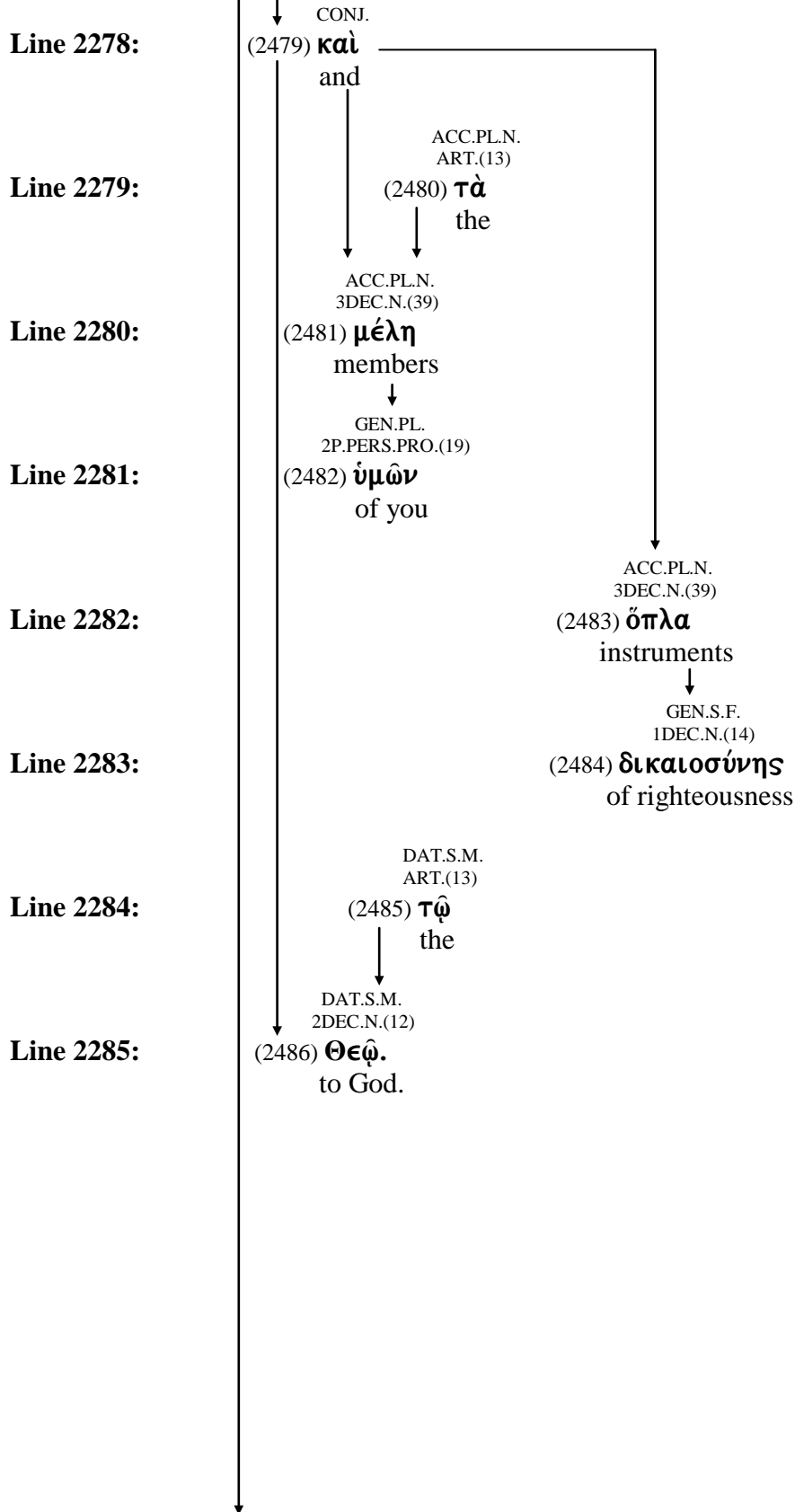

(2479) **καί** - conjunction = and, also, even

(2480) **ὁ** - article = the

(2481) **μέλος** = a member, limb, any part of the body

(2482) **σύ** - second person personal pronoun = you

(2483) **ὄπλον** = a weapon, instrument, tool, armor

(2484) **δικαιοσύνη** = righteousness, justice

from **δίκαιος** - adjective = righteous, just

from **δίκη** = justice, punishment

from **δεικνύω** = to show, to point out

(2485) **ὁ** - article = the

(2486) **θεός** = God, deity

**Romans 6:14** ἁμαρτία γὰρ ὑμῶν οὐ κυριεύσει· οὐ γὰρ ἐστε ὑπὸ νόμον, ἀλλ' (ἀλλὰ) ὑπὸ χάριν.

**Romans 6:14 Diagram**

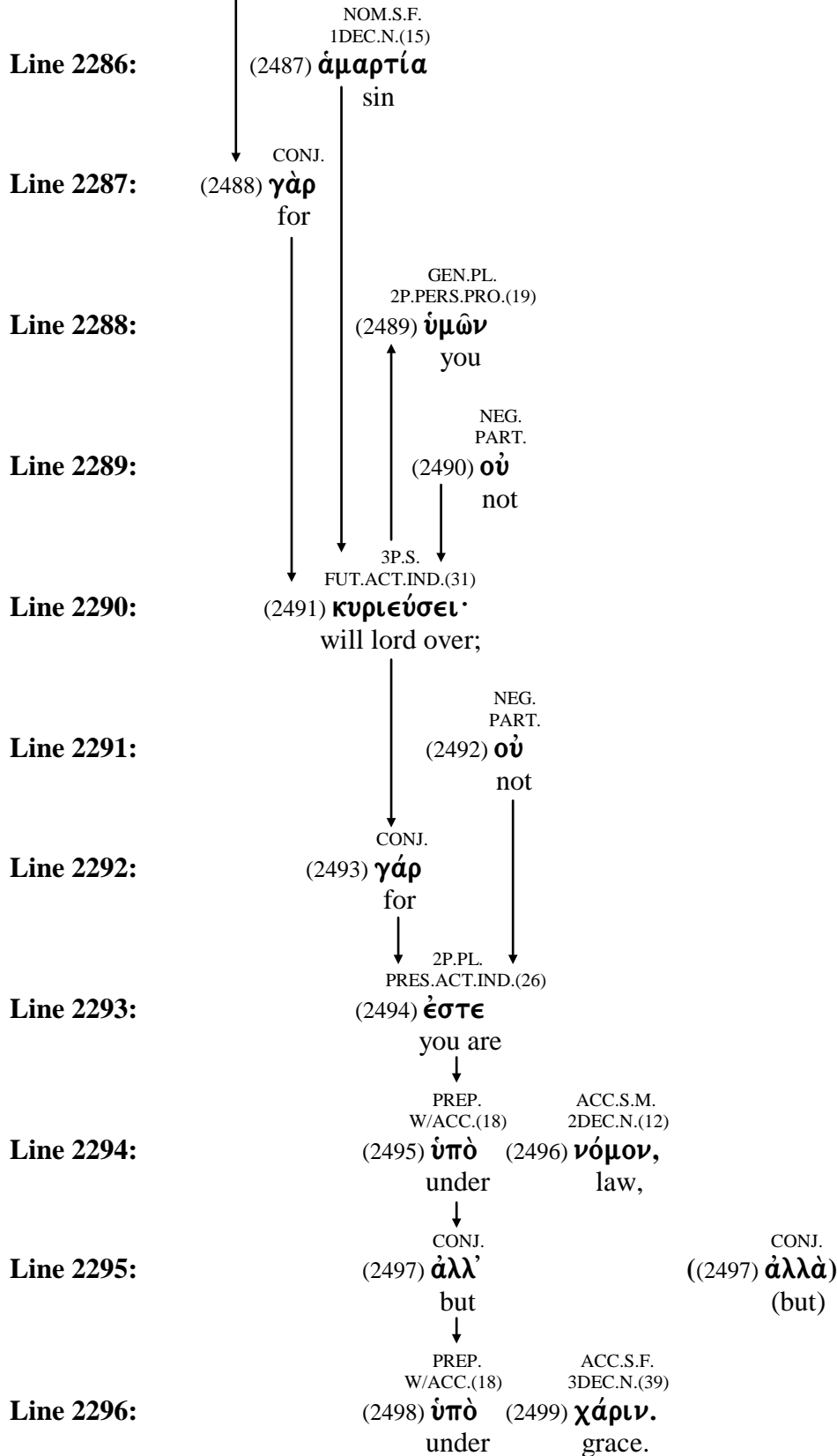

- (2487) **ἁμαρτία** = to miss the mark  
from **ἁμαρτάνω** = sin, trespass
- (2488) **γάρ** - conjunction = for
- (2489) **σύ** - second person personal pronoun = you
- (2490) **οὐ** - negative particle = no, not
- (2491) **κυριεύω** = to lord or rule over  
from **κύριος** = lord, master
- (2492) **οὐ** - negative particle = no, not
- (2493) **γάρ** - conjunction = for
- (2494) **εἰμί** = to be, exist
- (2495) **ὑπό** - preposition = by, under
- (2496) **νόμος** = a law, a command, anything established
- (2497) **ἄλλος** - adjective = another, other
- (2498) **ὑπό** - preposition = by, under
- (2499) **χάρις** = grace  
from **χαίρω** = rejoice

