

Lesson Twenty-One

Romans 5:18-21

18) ἄρα οὖν ὡς δι' ἑνὸς παραπτώματος εἰς πάντας ἀνθρώπους
then therefore as through one trespass for all men

εἰς κατάκριμα, οὕτω(ς) καὶ δι' ἑνὸς δικαιοῦματος εἰς
for condemnation, in this way also through One righteousness for

πάντας ἀνθρώπους εἰς δικαίωσιν ζωῆς.
all men for justification of life.

19) ὥσπερ γὰρ διὰ τῆς παρακοῆς τοῦ ἑνὸς ἀνθρώπου ἁμαρτωλοὶ
as indeed for through the disobedience the one of man sinners

κατεστάθησαν οἱ πολλοί, οὕτω(ς) καὶ διὰ τῆς ὑπακοῆς τοῦ
were established the many, in this way also through the obedience the

ἑνὸς δίκαιοι κατασταθήσονται οἱ πολλοί.
of one righteous will be established the many.

20) νόμος δὲ παρεῖσηθεν, ἵνα πλεονάσῃ τὸ παράπτωμα· οὐ
law and entered, in order that might abound the trespass; where

δὲ ἐπλεόνασεν ἡ ἁμαρτία, ὑπερεπερίσσευσεν ἡ χάρις·
and abounded the sin, over abounded the grace;

- 21) ἵνα ὥσπερ ἐβασίλευσεν ἡ ἁμαρτία ἐν τῷ θανάτῳ,
in order that as indeed ruled the sin in the death,
οὕτω(ς) καὶ ἡ χάρις βασιλεύσῃ διὰ δικαιοσύνης εἰς ζωὴν
in this way also the grace might rule through righteousness for life
αἰώνιον, διὰ Ἰησοῦ Χριστοῦ τοῦ Κυρίου ἡμῶν.
eternal, through Jesus Christ the Lord of us.

Word Association Diagram
Romans 5:18-21

VERSE 18

Line 2018:

Line 2019:

Line 2020:

Line 2021:

Line 2022:

Line 2023:

Line 2024:

Line 2025:

Line 2026:

Line 2027:

Line 2028:

Line 2029:

Line 2030:

Line 2031:

Line 2032:

Line 2033:

Line 2034:

Line 2035:

Line 2036:

Line 2037:

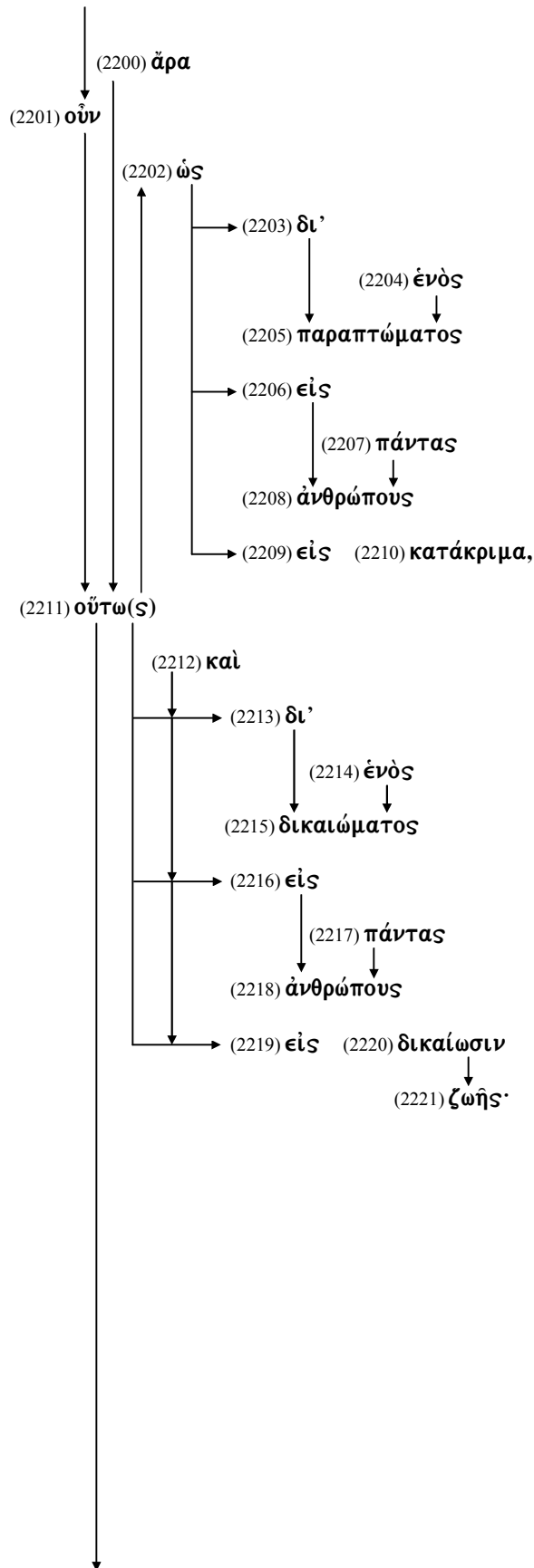

VERSE 19

Line 2038:

Line 2039:

Line 2040:

Line 2041:

Line 2042:

Line 2043:

Line 2044:

Line 2045:

Line 2046:

Line 2047:

Line 2048:

Line 2049:

Line 2050:

Line 2051:

Line 2052:

Line 2053:

Line 2054:

Line 2055:

Line 2056:

Line 2057:

Line 2058:

Line 2059:

Line 2060:

VERSE 20

Line 2061:

Line 2062:

Line 2063:

Line 2064:

Line 2065:

Line 2066:

Line 2067:

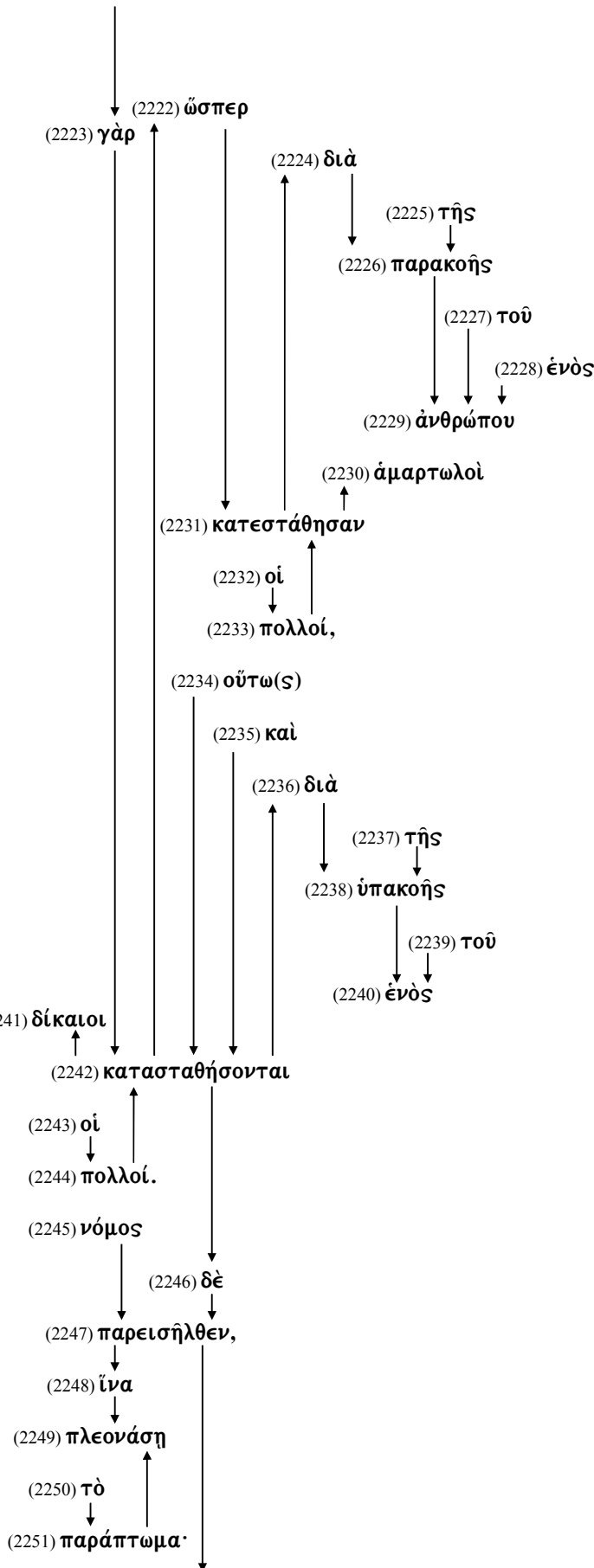

Word Association Diagram
Romans 5:18-21

VERSE 20 (cont.)

Line 2068:

Line 2069:

Line 2070:

Line 2071:

Line 2072:

Line 2073:

Line 2074:

Line 2075:

VERSE 21

Line 2076:

Line 2077:

Line 2078:

Line 2079:

Line 2080:

Line 2081:

Line 2082:

Line 2083:

Line 2084:

Line 2085:

Line 2086:

Line 2087:

Line 2088:

Line 2089:

Line 2090:

Line 2091:

Line 2092:

Line 2093:

Line 2094:

Line 2095:

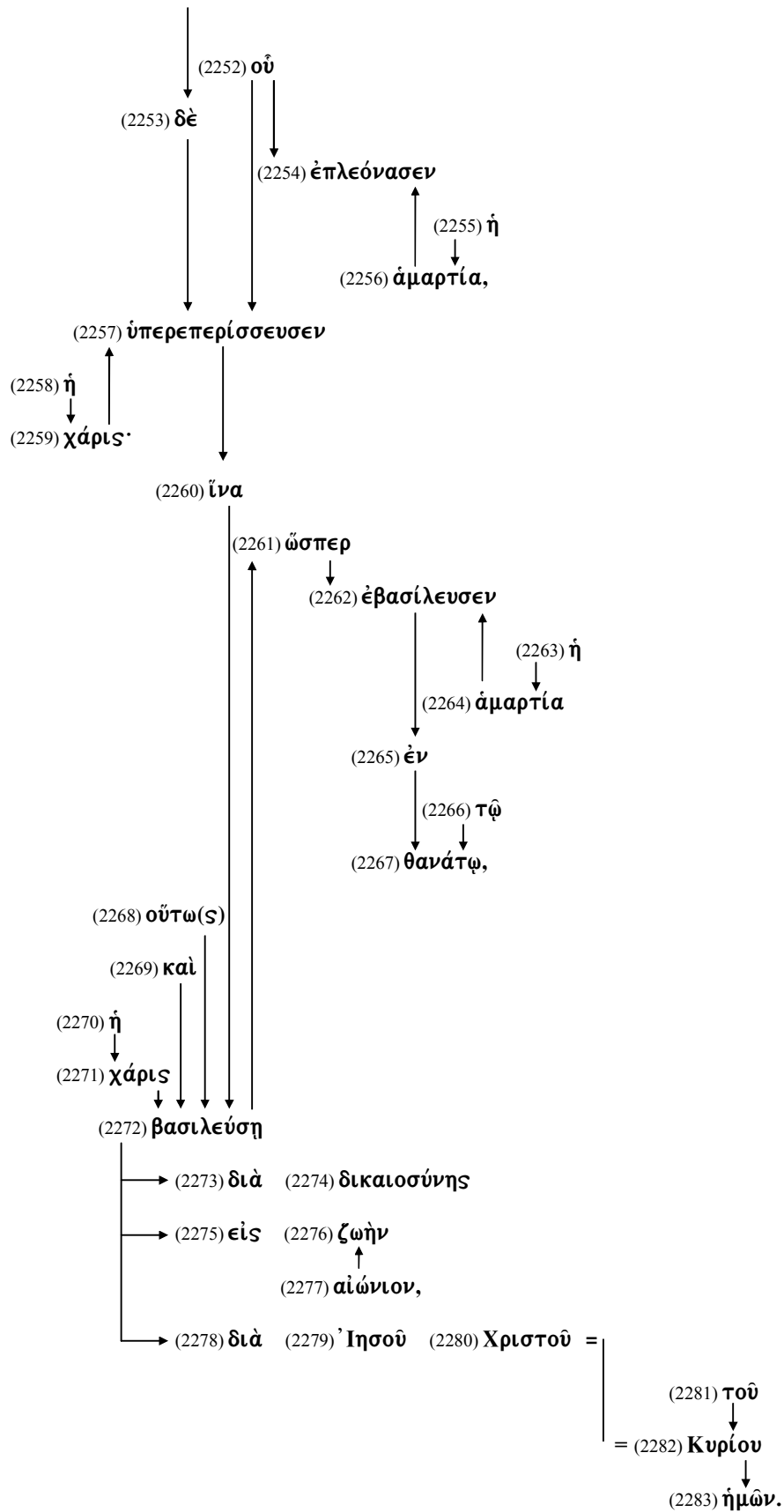

Lesson Twenty-One

Romans 5:18-21

Diagrams

Romans 5:18 Diagram

Romans 5:18 ἄρα οὖν ὡς δι' ἑνὸς παραπτώματος εἰς πάντας ἀνθρώπους εἰς κατάκριμα, οὕτω(ς) καὶ δι' ἑνὸς δικαίωματος εἰς πάντας ἀνθρώπους εἰς δικαίωσιν ζωῆς·

Line 2018:

CONJ.
(2200) ἄρα
then

Line 2019:

CONJ.
(2201) οὖν
therefore

Line 2020:

CONJ.
(2202) ὡς
as

Line 2021:

PREP.
W/GEN.(18)
(2203) δι'
through

Line 2022:

GEN.S.M.
NUM.(66)
(2204) ἑνὸς
one

Line 2023:

GEN.S.N.
3DEC.N.(40)
(2205) παραπτώματος
trespass

Line 2024:

PREP.
W/ACC.(18)
(2206) εἰς
for

Line 2025:

ACC.PL.M.
3DEC.N.(56)
(2207) πάντας
all

Line 2026:

ACC.PL.M.
2DEC.N.(12)
(2208) ἀνθρώπους
men

Line 2027:

PREP.
W/ACC.(18) ACC.S.N.
3DEC.N.(40)
(2209) εἰς (2210) κατάκριμα,
for condemnation,

- (2200) **ἄρα** - particle used for drawing a conclusion = then
from **αἶρω** = to lift or raise up
- (2201) **οὖν** - particle = therefore, then
- (2202) **ὥς** - adverb used as a comparative particle = as, like
from **ὅς** - relative pronoun = who, which, what
- (2203) **διά** - preposition used with the genitive = through
- (2204) **εἰς** - numeral = one
- (2205) **παράπτωμα** = a trespass, an offence; to fall beside something
from **παραπίπτω** = to fall beside, to fall away
from **παρά** - preposition = from, along side of, near
and **πίπτω** = to fall
- (2206) **εἰς** - numeral = one
- (2207) **πᾶς** - adjective = all, every
- (2208) **ἄνθρωπος** = a man, a human being
from **ἄνήρ** = a male
and **ὄψ** = the face or countenance
- (2209) **εἰς** - numeral = one
- (2210) **κατάκριμα** = condemnation, punishment
from **καταφρίνω** = to condemn
from **κατά** - preposition = according to, against
from **κρίνω** = to judge

Romans 5:18 Diagram

Romans 5:18 ἄρα οὖν ὡς δι' ἑνὸς παραπτώματος εἰς πάντας ἀνθρώπους εἰς κατάκριμα, οὕτω(ς) καὶ δι' ἑνὸς δικαίωματος εἰς πάντας ἀνθρώπους εἰς δικαίωσιν ζωῆς·

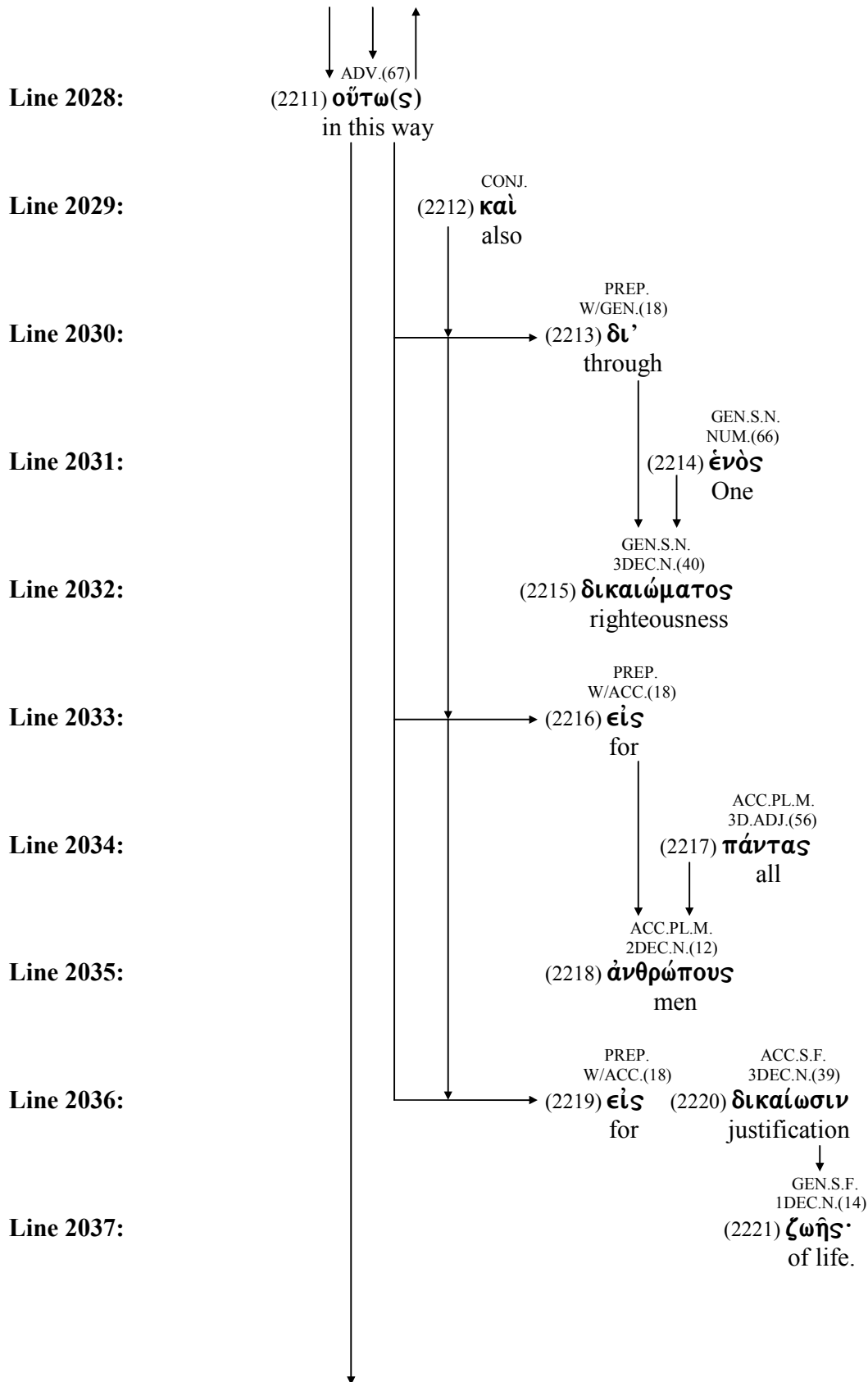

- (2211) **οὕτως** - adverb = so, thus, in this manner
from **οὗτος** - demonstrative pronoun = this
- (2212) **καί** - conjunction = and, also, even
- (2213) **διά** - preposition used with the genitive = through
- (2214) **εἰς** - numeral = one
- (2215) **δικαίωμα** = righteous act, requirement, ordinance
from **δικαιόω** = to justify, to make righteous
from **δίκαιος** - adjective = righteous, just
from **δίκη** = justice, punishment
- (2216) **εἰς** - numeral = one
- (2217) **πᾶς** - adjective = all, every
- (2218) **ἄνθρωπος** = a man, a human being
from **ἄνθρωπος** = a male
and **ὄψ** = the face or countenance
- (2219) **εἰς** - numeral = one
- (2220) **δικαίωσις** = justification, acquittal
from **δικαιόω** = to justify, to make righteous
from **δίκαιος** - adjective = righteous, just
from **δίκη** = justice, punishment
- (2221) **ζωή** = life
from **ζάω** = to live, to breathe

Romans 5:19 Diagram

Romans 5:19 ὥσπερ γὰρ διὰ τῆς παρακοῆς τοῦ ἐνὸς ἀνθρώπου ἁμαρτωλοὶ κατεστάθησαν οἱ πολλοί, οὕτω(ς) καὶ διὰ τῆς ὑπακοῆς τοῦ ἐνὸς δίκαιοι κατασταθήσονται οἱ πολλοί.

Line 2038:

CONJ.
(2222) ὥσπερ
as indeed

Line 2039:

CONJ.
(2223) γὰρ
for

Line 2040:

PREP.
W/GEN.(18)
(2224) διὰ
through

Line 2041:

GEN.S.F.
ART.(13)
(2225) τῆς
the

Line 2042:

GEN.S.F.
1DEC.N.(14)
(2226) παρακοῆς
disobedience

Line 2043:

GEN.S.M.
ART.(13)
(2227) τοῦ
the

Line 2044:

GEN.S.M.
NUM.(66)
(2228) ἐνὸς
one

Line 2045:

GEN.S.M.
2DEC.N.(12)
(2229) ἀνθρώπου
of man

Line 2046:

NOM.PL.M
3D.ADJ.(56)
(2230) ἁμαρτωλοὶ
sinners

Line 2047:

AOR.PASS.IND.(37)
(2231) κατεστάθησαν
were established

Line 2048:

NOM.PL.M.
ART.(13)
(2232) οἱ
the

Line 2049:

NOM.PL.M.
3D.ADJ.(56)
(2233) πολλοί,
many,

- (2222) **ὥσπερ** - conjunction = as indeed
from **ὡς** - adverb = as, like
from **ὃς** - relative pronoun = who, which, what
and **περ** - particle denoting abundance
from **πέραν** - adverb = beyond
- (2223) **γάρ** - conjunction = for
- (2224) **διά** - preposition used with the genitive = through
- (2225) **ὁ** - article = the
- (2226) **παρακοή** = failing to hear, unwilling to hear, disobedience
from **παρακούω** = inattention
from **παρά** - preposition = near, alongside of, contrary
and **ἀκούω** = to hear
- (2227) **ὁ** - article = the
- (2228) **εἷς** - numeral = one
- (2229) **ἄνθρωπος** = a man, a human being
from **ἀνήρ** = a male
and **ὄψ** = the face or countenance
- (2230) **ἁμαρτωλός** - adjective = sinner
from **ἁμαρτάνω** = to sin
from **α** - used as a negative particle = without
and **μέρος** = part, section, allotment
- (2231) **καθίστημι** = to set, to appoint
from **κατά** - preposition = according to, against, down
and **ἵστημι** = to stand, to appoint
- (2232) **ὁ** - article = the
- (2233) **πολύς** - adjective = many, much, large

Romans 5:19 Diagram

Romans 5:19 ὥσπερ γὰρ διὰ τῆς παρακοῆς τοῦ ἑνὸς ἀνθρώπου ἁμαρτωλοὶ κατεστάθησαν οἱ πολλοί, οὕτω(ς) καὶ διὰ τῆς ὑπακοῆς τοῦ ἑνὸς δίκαιοι κατασταθήσονται οἱ πολλοί.

Line 2050:

ADV.(67)
(2234) οὕτω(ς)
in this way

Line 2051:

CONJ.
(2235) καὶ
also

Line 2052:

PREP.
W/GEN.(18)
(2236) διὰ
through

Line 2053:

GEN.S.F.
ART.(13)
(2237) τῆς
the

Line 2054:

GEN.S.F.
1DEC.N.(14)
(2238) ὑπακοῆς
obedience

Line 2055:

GEN.S.M.
ART.(13)
(2239) τοῦ
the

Line 2056:

GEN.S.M.
NUM.(66)
(2240) ἑνὸς
of one

Line 2057:

NOM.PL.M.
ADJ.(17)
(2241) δίκαιοι
righteous

Line 2058:

FUT.PASS.IND.(38)
(2242) κατασταθήσονται
will be established

Line 2059:

NOM.PL.M.
ART.(13)
(2243) οἱ
the

Line 2060:

NOM.PL.M.
3D.ADJ.(56)
(2244) πολλοί.
many.

- (2234) **οὕτως** - adverb = so, thus, in this manner
from **οὗτος** - demonstrative pronoun = this
- (2235) **καί** - conjunction = and, also, even
- (2236) **διά** - preposition used with the genitive = through
- (2237) **ὁ** - article = the
- (2238) **ὑπακοή** = obedience, responsive
from **ὡς** - adverb = as, like
from **ὅς** - relative pronoun = who, which, what
and **περ** - particle denoting abundance
- (2239) **ὁ** - article = the
- (2240) **εἷς** - numeral = one
- (2241) **δίκαιος** - adjective = just, right, righteous
from **δίκη** = justice, punishment
- (2242) **καθίστημι** = to set, to appoint
from **κατά** - preposition = according to, against, down
and **ἵστημι** = to stand, to appoint
- (2243) **ὁ** - article = the
- (2244) **πολύς** - adjective = many, much, large

Romans 5:20 Diagram

Romans 5:20 νόμος δὲ παρῆλθεν, ἵνα πλεονάσῃ τὸ παράπτωμα· οὐ δὲ ἐπλέονασεν ἡ ἁμαρτία, ὑπερεπερίσσευσεν ἡ χάρις·

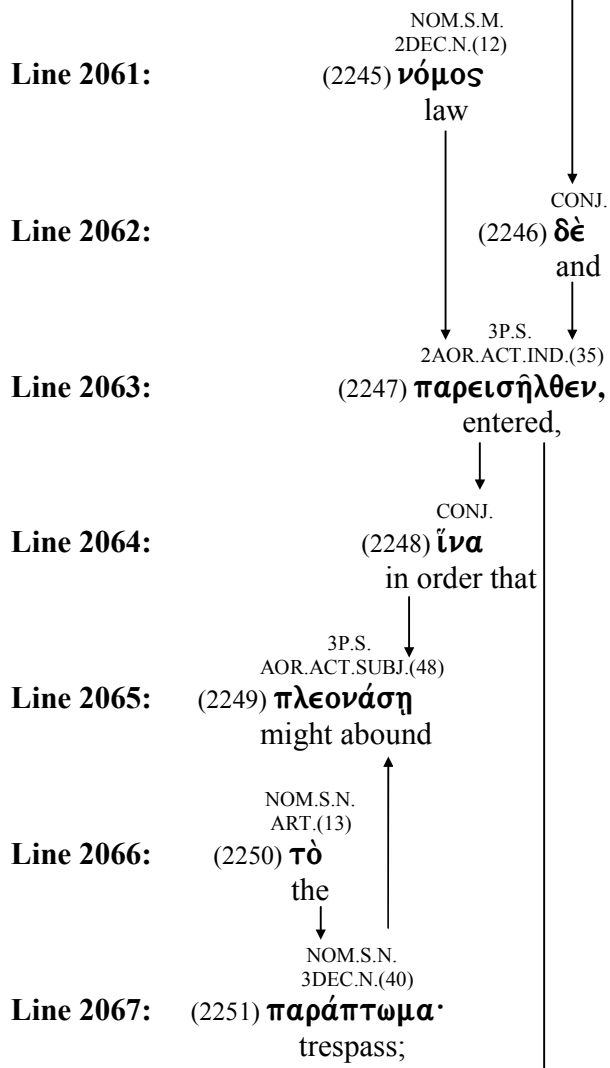

(2245) **νόμος** = a law, a command, anything established

(2246) **δὲ** - conjunction = and, now, even

(2247) **παρεισέρχομαι** = to slip in, to enter in
from **παρά** - preposition = near, alongside of, contrary
and **εἰσέρχομαι** = to enter
from **εἰς** - preposition = into, toward
and **έρχομαι** = to come, to go

(2248) **ἵνα** - conjunction = that, in order that

(2249) **πλεονεξία** = a greedy desire to have more
from **πλεονέκτης** = one who desires to have more
from **πολύς** – adjective = more, many
and **έχω** = to have

(2250) **ὁ** - article = the

(2251) **παράπτωμα** = a trespass, an offence; to fall beside something
from **παραπίπτω** = to fall beside, to fall away
from **παρά** - preposition = from, along side of, near
and **πίπτω** = to fall

Romans 5:20 Diagram

Romans 5:20 νόμος δὲ παρεισῆλθεν, ἵνα πλεονάσῃ τὸ παράπτωμα· οὐ δὲ ἐπλεόνασεν ἡ ἁμαρτία, ὑπερεπερίσσευσεν ἡ χάρις·

Line 2068:

ADV.(67)
(2252) οὐ
where

Line 2069:

CONJ.
(2253) δὲ
and

Line 2070:

3P.S.
AOR.ACT.IND.(33)
(2254) ἐπλεόνασεν
abounded

Line 2071:

NOM.S.F.
ART.(13)
(2255) ἡ
the

Line 2072:

NOM.S.F.
1DEC.N.(15)
(2256) ἁμαρτία,
sin,

Line 2073:

3P.S.
AOR.ACT.IND.(33)
(2257) ὑπερεπερίσσευσεν
over abounded

Line 2074:

NOM.S.F.
ART.(13)
(2258) ἡ
the

Line 2075:

NOM.S.F.
3DEC.N.(39)
(2259) χάρις·
grace;

(2252) **οὐ** - negative particle = no, not

(2253) **δὲ** - conjunction = and, now, even

(2254) **πλεονάζω** = to increase, to exceed
from **πλείων** - adjective = more, excel
and **πολύς** - adjective = great, much

(2255) **ὁ** - article = the

(2256) **ἁμαρτία** = to miss the mark
from **ἁμαρτάνω** = sin, trespass

(2257) **ὑπερπερισσεύω** = to greatly increase, to cause to overflow
from **ὑπέρ** - preposition = above, abundant
and **περισσεύω** = to abound
from **περισσός** - adjective = abundant
from **περί** - preposition = concerning, around

(2258) **ὁ** - article = the

(2259) **χάρις** = grace
from **χαίρω** = rejoice

Romans 5:21 Diagram

Romans 5:21 ἵνα ὡσπερ ἐβασίλευσεν ἡ ἁμαρτία ἐν τῷ θανάτῳ, οὕτω(ς) καὶ ἡ χάρις βασιλεύσῃ διὰ δικαιοσύνης εἰς ζωὴν αἰώνιον, διὰ Ἰησοῦ Χριστοῦ τοῦ Κυρίου ἡμῶν.

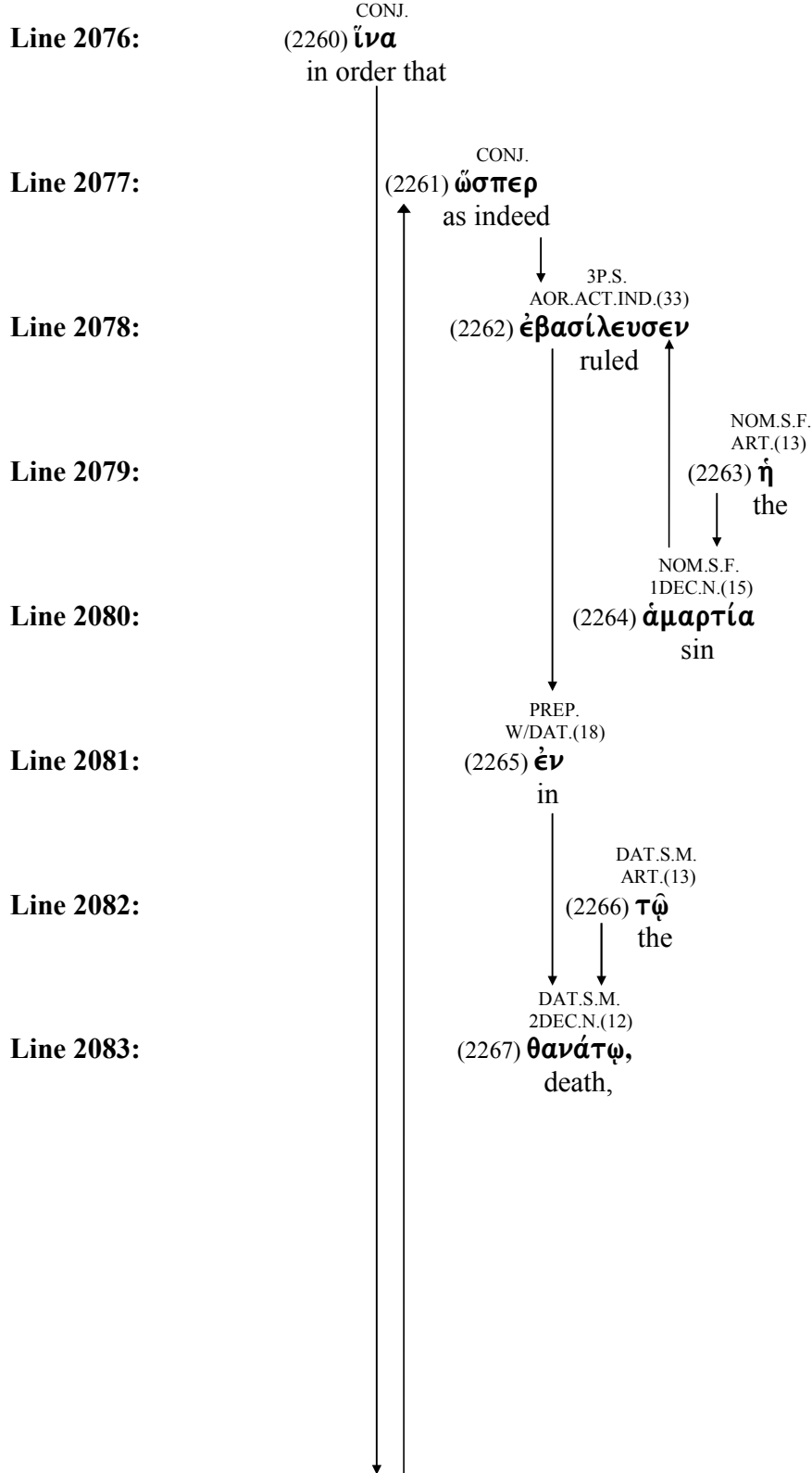

(2260) **ἵνα** - conjunction = that, in order that

(2261) **ὥσπερ** - conjunction = as indeed
from **ὡς** - adverb = as, like
from **ὃς** - relative pronoun = who, which, what
and **περ** - particle denoting abundance
from **πέραν** - adverb = beyond

(2262) **βασιλεύω** = to reign, to rule
from **βασιλεύς** = a king
from **βάσις** = step, foot

(2263) **ὁ** - article = the

(2264) **ἁμαρτία** = to miss the mark
from **ἁμαρτάνω** = sin, trespass

(2265) **ἐν** - preposition used with the dative = in

(2266) **ὁ** - article = the

(2267) **θάνατος** = death
from **θνήσκω** = to die

Romans 5:21 ἵνα ὡσπερ ἐβασίλευσεν ἡ ἁμαρτία ἐν τῷ θανάτῳ, οὕτω(ς) καὶ ἡ χάρις βασιλεύσῃ διὰ δικαιοσύνης εἰς ζωὴν αἰώνιον, διὰ Ἰησοῦ Χριστοῦ τοῦ Κυρίου ἡμῶν.

Romans 5:21 Diagram

Line 2084: (2268) οὕτω(ς)
ADV.(67)
in this way

Line 2085: (2269) καὶ
CONJ.
also

Line 2086: (2270) ἡ
NOM.S.F.
ART.(13)
the

Line 2087: (2271) χάρις
NOM.S.F.
3DEC.N.(39)
grace

Line 2088: (2272) βασιλεύσῃ
AOR.ACT.SUBJ.(48)
might rule

Line 2089: (2273) διὰ (2274) δικαιοσύνης
PREP. W/GEN.(18) GEN.S.F. 1DEC.N.(14)
through righteousness

Line 2090: (2275) εἰς (2276) ζωὴν
PREP. W/ACC.(18) ACC.S.F. 1DEC.N.(14)
for life

Line 2091: (2277) αἰώνιον,
ACC.S.F. 3D.ADJ.(56)
eternal,

Line 2092: (2278) διὰ (2279) Ἰησοῦ (2280) Χριστοῦ =
PREP. W/GEN.(18) GEN.S.M. PROP.NM.(65) GEN.S.M. 2DEC.N.(12)
through Jesus Christ

Line 2093: (2281) τοῦ
GEN.S.M. ART.(13)
the

Line 2093: = (2282) Κυρίου
GEN.S.M. 2DEC.N.(12)
Lord

Line 2093: (2283) ἡμῶν.
GEN.S. 1P.PERS.PRO.(19)
of us.

- (2268) **οὕτως** - adverb = so, thus, in this manner
from **οὗτος** - demonstrative pronoun = this
- (2269) **καί** - conjunction = and, also, even
- (2270) **ὁ** - article = the
- (2271) **χάρις** = grace
from **χαίρω** = rejoice
- (2272) **βασιλεύω** = to reign, to rule
from **βασιλεύς** = a king
from **βάσις** = step, foot
- (2273) **διά** - preposition used with the genitive = through
- (2274) **δικαιοσύνη** = righteousness
from **δίκαιος** = righteous, just, right
from **δίκη** = judgment, execution of a sentence, punishment
- (2275) **εἰς** - preposition used with the accusative = to, unto, towards
- (2276) **ζωή** = life
from **ζάω** = to live, to breathe
- (2277) **αἰώνιος** - adjective = unlimited duration, eternal, forever
from **αἰών** = ever, eternal
- (2278) **διά** - preposition used with the genitive = through
- (2279) **Ἰησοῦς** = Jesus
of Hebrew origin - from Joshua or Jehoshua = "Yahweh is salvation"
from Yahweh = "the existing One"
from the Hebrew word translated "to be, become, come to"
and "to save, be saved, be delivered, to rescue"
- (2280) **Χριστός** = Christ
meaning "anointed" - from **χρίω** = to anoint
- (2281) **ὁ** - article = the
- (2282) **κύριος** = lord, master
from **κύρος** = supremacy
- (2283) **ἐγώ** - first person personal pronoun = I

